

# Hybrid Control of Microgrid with PV, Diesel Generator and BESS

Swaminathan Ganesan<sup>\*</sup>, Ramesh V<sup>\*</sup>, Umashankar S<sup>\*‡</sup>

<sup>\*</sup>School of Electrical Engineering, VIT University, Vellore, 632014, India  
(gswami@yahoo.co.in, vramesh@vit.ac.in, umashankar.s@vit.ac.in)

<sup>‡</sup>Corresponding Author; Umashankar S, School of Electrical Engineering, VIT University, Vellore, 632014, India,  
Tel: +919003260199, umashankar.s@vit.ac.in

*Received: 15.02.2017 Accepted:24.02.2017*

**Abstract-** The PV diesel hybrid controller benefits in higher reliability of operation, less pollution, reduction in operating cost, and enhanced system life. In this paper, the authors have proposed a robust hybrid controller to manage the power sharing among PV generator, Diesel generator and energy storage unit in a microgrid network. With the higher penetration of renewable energy sources into the system, the need for robust hybrid controller to tackle highly intermittent nature of available power. The proposed hybrid control scheme facilitates optimum power sharing between the sources based on the dynamics of photo voltaic energy available at any given time. The changes in generation are mainly due to the intermittent nature of PV source and level of stored energy in battery. The hybrid power flow control has been realized by controlling the active power generated by the PV inverter and diesel generator as a function of the system frequency in the islanded mode of microgrid operation. A stand-alone controller has been developed to demonstrate the power flow control to envisage the saving in fuel consumption as well as highly reliable operation.

**Keywords:** Hybrid controller, Microgrid, Diesel abatement, Power curtailment

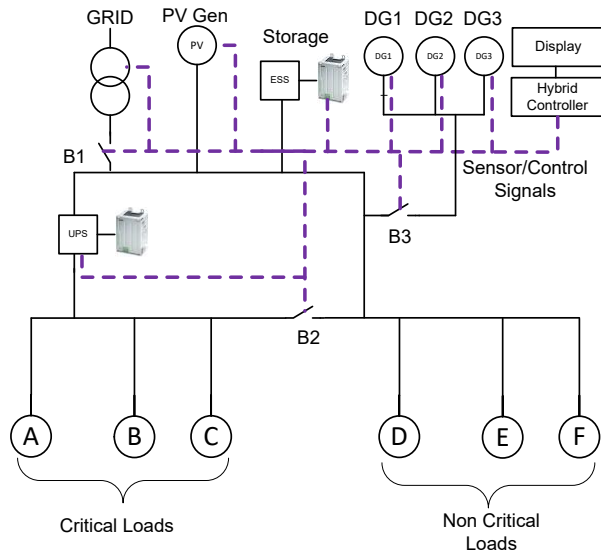
## 1. Introduction

The aggregation of renewable energy sources like solar, wind, traditional diesel generator and utility grid along with storage devices constitutes Microgrid [1]-[3]. The penetration of sustainable energy sources aids in reducing carbon foot print and in turn brings down the global warming. In present day scenario the majority of global population predominantly depending upon traditional source of energy, such as Coal fired thermal power plant, Oil and natural gas powered plants. Since the energy demand is increasing with increase in per capita energy consumption of the world, the conventional energy sources reserves are getting depleted at a rapid pace. This situation enforcing for a technology disruption and necessitates the integration of sustainable sources of energy into the regular energy network [4]. The new government sponsored drives like, introduction of federal tax incentives, feed in tariffs are the main motivating factors for fast growth in penetration of PV source and increased participation of consumers. The introduction of hybrid controller will reduce the diesel consumption and at the same time maintaining the spinning reserve of diesel generator (DG) to avoid intermittency. This

will be the ideal solution for installations with 20 to 60% PV penetration and with the diesel cost is >1\$ per liter. If the DG's are running continuously, then PV source has significant potential to reduce the diesel consumption. The DG has to be operated always with minimum load, accordingly the PV generation to be curtailed as per equation (1) [5].

$$PV_{max} = Total\ Load - DG_{min} \quad (1)$$

The Fig. 1 shows the proposed microgrid system with hybrid controller. There are three circuit breakers B1, B2 and B3 to control the source and loads into the network. All the control signals and input signal to the hybrid controller are connected through Modbus RS485 protocol. The loads are classified into critical and non-critical types. All the critical loads are served through UPS. The DG's are connected to the network through circuit breaker B3. B1 is used to control the utility connection and B2 is used to control critical and non-critical load sections. The proposed microgrid network contains storage system in addition to the UPS [7][8].



**Fig. 1.** Microgrid System with Hybrid controller

**2. Problem Definition**

With grid tied PV generators connected in the power system network, if utility grid goes off, the PV generator will cease operation, as the solar power cannot operate as a stand-alone energy source. The DG’s will become active and start serving loads. In general, the grid tied PV generators are not designed to operate in off grid mode with DG’s to share the loads. This will eventually increase the fuel consumption and cost of energy, as the entire load to be served by DG’s until utility grid restoration. To make the grid tied PV generators to operate along with DG’s in off grid mode, the hybrid controllers are required which will detect the absence of main grid and communicate with both DG and PV generators to synchronize both the sources and ensure the reliable operation of microgrid by providing proper reference voltage and frequency parameters over the microgrid network. The authors proposed a robust hybrid controller and control strategy to envisage the aforementioned functionality.

**3. System Configuration**

Table. 1. lists configuration of the proposed microgrid under consideration. The loads that are classified under non critical (shed-able) are managed during the off grid mode, hence they are not factored during islanded operation. All the critical loads are fed through UPS hence they are not fully dependent on DG’s or PV generator in off grid mode.

**4. Hybrid Controller Design**

The hybrid controller designed to perform power flow management and control over the microgrid to ensure reliable operation and smooth load dispatch. The controller

ensures DGs operate always above the minimum generator load required, in order to maintain the minimum DG power conversion losses [6]. Also the to protect DGs from reverse power feedback, the PV generator output is curtailed.

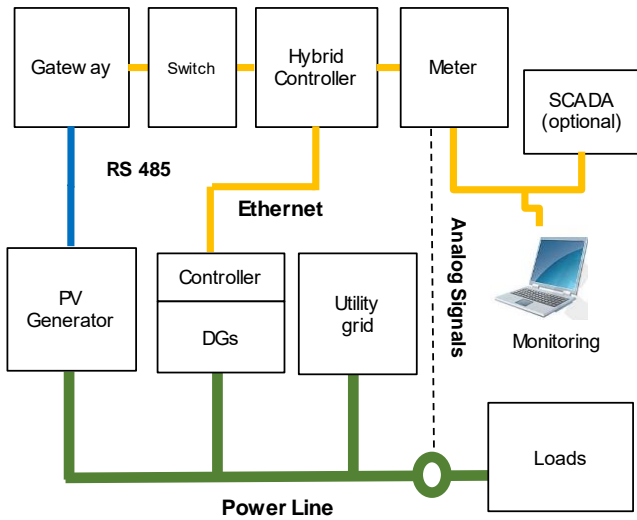
Spinning reserve to be maintained to manage large step change in PV production output. In case of sudden clouds, the PV generation will drop, such sudden loss can be as high as 80% of installed PV capacity and the ramp down will be within 6 seconds. Preventing DGs from frequent start-stop cycles, to minimize maintenance costs and to ensure longevity of the DGs. CPU TM258LD processor has been used to develop the control algorithm to perform the hybrid control activities. The Fig. 2. shows the block diagram of the microgrid system with hybrid controller.

**Table. 1.** Configuration of Microgrid system

Microgrid system capacity	25 kVA, 400 V – 3PH + N, TT grounding
PV generation	20 kVA, 400V, 3 PH, 4 wire transformerless
Battery storage	1200 Ah, 5 kW
Diesel Generator	10 kVA, 400V – 3PH, 4 wire
UPS - Online	10 kVA, 400V, 3PH, 4 wire
Critical loads (3-ph)	400V, - 3PH+N: 8 kVA, PF 0.93
Non critical loads (1-Ph)	Ph 1-N 230 V, Lighting, 7 kVA, PF 0.7
Non critical loads (1-Ph)	Ph 2-N 230 V, Air condition: 7 kVA, PF 0.7
Non critical loads (1-Ph)	Ph 3-N 230 V, Lighting: 7 kVA, PF 0.7

The physical analog signals from power line are acquired by a power meter and fed to hybrid controller. The controller processes the data and sends the control signals to PV generator and DG’s appropriately over the network through Ethernet or RS485 protocol. The active power threshold limit activation mainly for limiting load sharing for activating an additional DG, Cut-out threshold limit control for deactivating a DG and control minimum load level for a DG to keep spinning reserve. The hybrid controller communicates with DG controller and PV generator over

Modbus RTU. The Modbus polling time between the controllers are configurable. The hybrid controller prevents reverse power flow from PV generator to DG, also zero export to grid if mandated by utility.



**Fig. 2.** Block diagram of Hybrid controller communication with other system components

The PV generators are designed with in built Phase Locked Loop (PLL) controllers to synchronize the PV generator phase to the utility main's or the reference voltage from DG's or BESS that are present in the network [9]. The equation 2 represents the three phase voltage waveform and equation 3 depicts the reference axis transformation of three phase grid voltage vectors (a,b,c) and their ab and d- q axis transformation voltages.

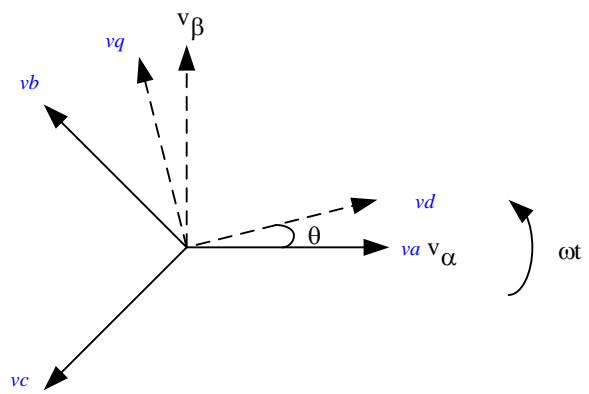
$$\begin{aligned}
 v_a &= V_m \cos(\omega t) \\
 v_b &= V_m \cos(\omega t - \frac{2\pi}{3}) \\
 v_c &= V_m \cos(\omega t - \frac{4\pi}{3}) \\
 \theta &= \omega t
 \end{aligned}$$

$$\begin{aligned}
 v_\alpha &= v_a \\
 v_\beta &= \frac{(v_b - v_c)}{\sqrt{3}}
 \end{aligned}
 \tag{3}$$

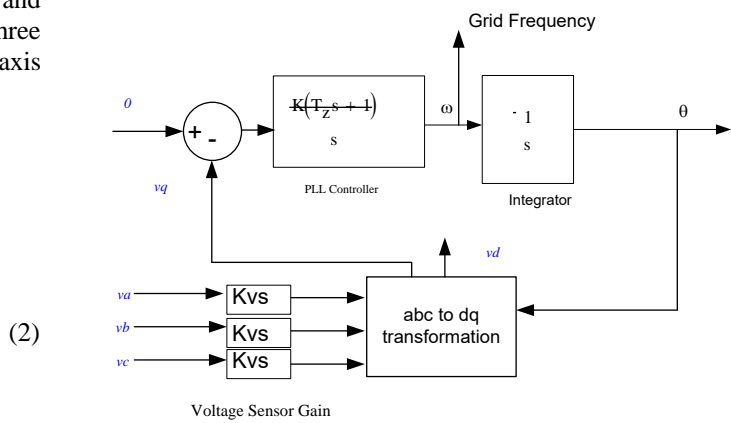
During islanded mode of operation, PV output may not cater to the complete load requirement, in that condition, the PV generator will have to AC couple with the AC outputs of off grid energy sources like non grid tied energy storage system or DG's.

$$\begin{aligned}
 v_d &= v_\alpha \cos \theta + v_\beta \sin \theta \\
 v_q &= -v_\alpha \sin \theta + v_\beta \cos \theta \\
 v_d &= V_m \cos(\omega t - \theta) \\
 v_q &= V_m \sin(\omega t - \theta)
 \end{aligned}
 \tag{4}$$

To achieve successful parallel operation, the in equation (4)



**Fig. 3.** d- q axis representation of three phase voltage vectors

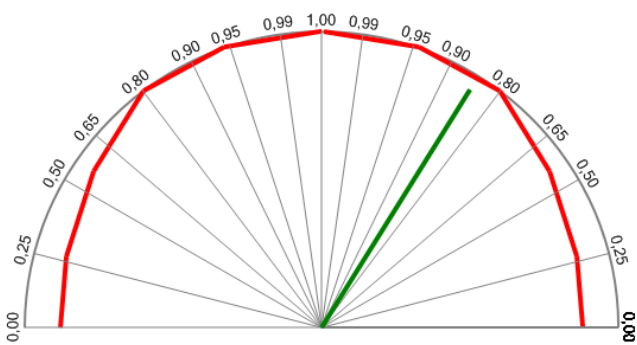


**Fig. 4.** Block diagram of proposed PLL controller

Grid tied PV generators are commonly designed to work on highly stable grids and needed to aggressively protect from destabilizing the grid under dynamic load conditions or when utility generation (grid formers) exhibits over or under excitation. This necessitates all the connected energy sources and sinks in a microgrid to exchange the demand and constraints effectively. The Fig. 4 shows the proposed PLL controller to achieve above mentioned operation through modulation of frequency at a common point of coupling with the combination of hybrid controller and PLL. The PLL control system has been implemented in digital signal processor TMS320F28335 and tested.

**5. Reactive Power Control**

In microgrid system in islanded condition, reactive power limitation is very critical for maintaining stability. In a distributed energy sources, if any of the source prioritize reactive power reference as against active power reference, this might lead to system oscillation. The hybrid controller will set the reactive power reference over the network based on the active power generation [10][11]. If the active power generation increases, then corresponding reactive power reference value will be increased by the controller. This will help to increase active power generation by PV generator if the inverter operates on its capability limits.



**Fig. 5.** Capability curve of PV generator

The Fig. 5. shows the capability curve of PV generator. The Fig. 6. shows the reactive power control and corresponding reference component generation. If the active power output of PV generator greater than zero, then Point of Common Coupling (PCC) will sink the real power, if the reactive power output of PV generator is less than zero, then the PCC sources reactive power. There are three different methods of reactive power control available in PV generators, i. Constant power factor control, ii. Power factor as a function of active power, and iii. Reactive power as a function of voltage, either of the one method can be activated to achieve stable system operation [12].

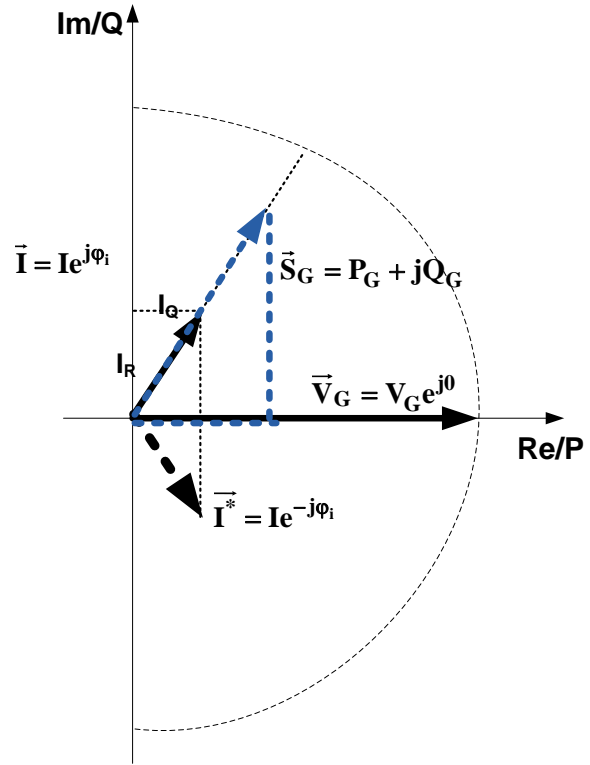
$$I_R = \sqrt{2}I_d \text{ Active Current component}$$

$$I_Q = \sqrt{2}I_q \text{ Reactive Current component} \tag{5}$$

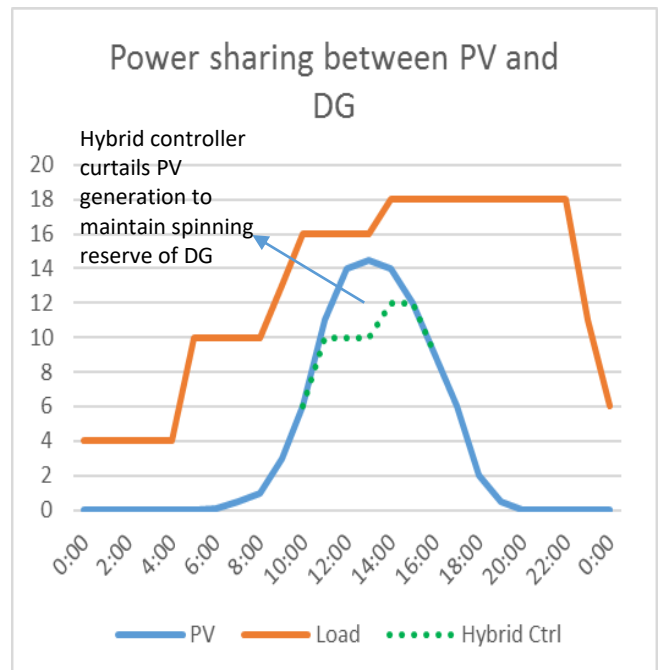
**6. Active Power Control**

The active power control in a microgrid system with PV generator and DG's are very critical to prevent reverse power flow from PV to DG's and to maintain spinning reserve of DG's for maintaining economic operation. In addition to this, proper active power control will reduce frequent switching of DG's. The Fig. 7 shows the active power sharing between PV generator and DG's. The PV power generation increases with increase in irradiation level. The load demand varies depends on the time of the day. During noon, the PV generation at its peak, during this time the majority of loads are supplied by PV source, but the DG's

will have to operate only with minimum load to have economic fuel consumption, this is required to manage intermittency of PV source. Hybrid controller limits the PV generation by setting active power reference value to PV generator [13].

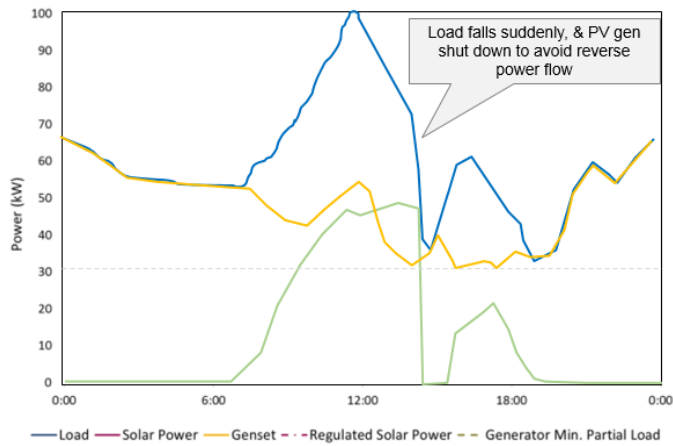


**Fig. 6.** Reactive power control & reference value calculation



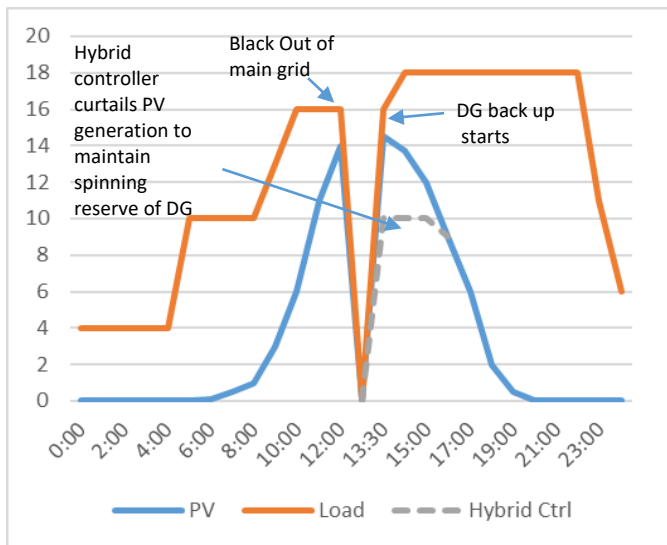
**Fig. 7.** Active power curtailment of PV generator during peak PV generation

The Figure 8. shows the Power sharing between PV generator and DG's in the event of sudden drop in load demand. In this scenario, instantaneous active power output of PV generator is equal or more than total demand, to maintain the continuity of power supply, the active power reference is set in such a way that the DG's always operation above spinning reserve level. In this case, the PV is completely shut off to avoid reverse power flow, as the load is lesser than PV generation. Once the load demand increases or the PV output reduces below spinning reserve level, the active power reference value is changed and PV source share the load along with DG[14].



**Fig. 8.** PV generator shut down during sudden drop in load demand

The Figure 9. shows the active power sharing for an another scenario where there is sudden black out of main grid, during this condition, the DG back up starts immediately and takes the entire load, once DG starts, PV connects to PCC and starts sharing load, but the PV generation is curtailed to maintain spinning reserve[15][16]. This will help the system sustain the operation during sudden clouding effect.



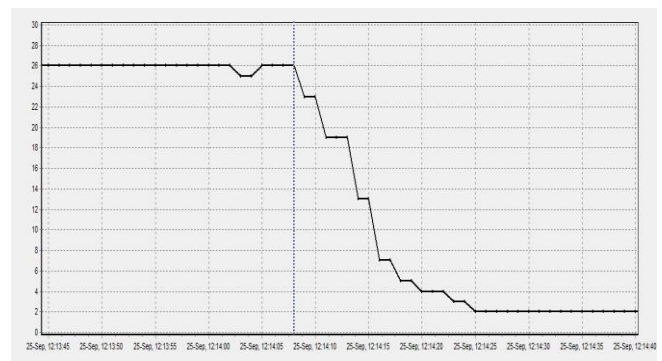
**Fig. 9.** PV output power curtailment during black out of utility

**7. Conclusion**

We discussed about the need for hybrid controller to save fuel consumption of DG's and design of hybrid controller to perform active and reactive power control in the microgrid during On grid as well as Off grid mode operation. The designed controller has been implemented and various operating conditions have been tested to verify the performance of the system. The Fig. 10. shows the hardware test set up the PV inverter connected with utility main and DG's. The resistive banks are used to emulate the sudden load variation in addition to the connected building loads. The PV simulation has been used to set the PV profile with different irradiation levels. The outcome of the test results are plotted in a graph and listed in table. For all the measurements, the sample rate is set at 50 kHz. The Fig. 11. shows the power management test of hybrid controller with the set ramp down rate of 20% per second, the the PV generator took 17 seconds to reach 2 kW power level from 26 kW without any oscillations.



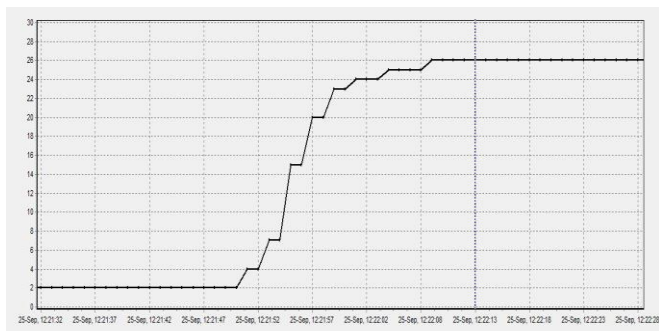
**Fig. 10.** Hardware test set up of PV generator with Hybrid controller



**Fig. 11.** Active power ramp down test for change in reference

The Fig. 12. shows the test results for increase in active power reference set value. The ramp up rate is set at 20% per second. The PV generator took 18 seconds to reach 26 kW power level from 2 kW without any oscillations. The following Tables list the results of reactive power management tests under various operating conditions in islanded mode of operation.





**Fig. 12.** Active power ramp up test for change in reference

Table 2. Shows the variation in reactive power from PV generator with fixed power factor setting of 0.8 leading and 0.8 lagging under varying active power generation. The reactive power varies proportionally in respective direction for the change in active power. The Table 3 shows the reactive power control for a fixed active power generation under varying power factor for capacitive and inductive. The results are confirmed to be the designed hybrid controller ensures precise power management of microgrid to maintain sustained operation of system under highly dynamic power conditions fluctuating between the extreme boundary conditions. The system stays stable and continues to dispatch power to loads without any oscillations. This work can be enhanced in future with more number of DG’s and PV generators connected in parallel with the addition of drooping control system for system improved stability and power sharing.

**Table 2** Reactive power management for fixed power factor

0.8 PF Leading		0.8 PF Lagging	
KW	KVAR	KW	KVAR
25	-12	25	7
20	-8	20	5
10	-4	10	4
5	1	5	1

**Table 3** Reactive power management for fixed active power

25 kW		25 kW	
Capacitive to Unity	KVAR	Inductive to Unity	KVAR
0.8 Lead	-11	0.8 Lag	10.9
0.85 Lead	-10.6	0.85 Lag	7
0.9 Lead	-9	0.9 Lag	4
0.95 Lead	1	0.95 Lag	1

**References**

[1] Gaurav, Sonal, Chirag Birla, Aman Lamba, S. Umashankar, and Swaminathan Ganesan. "Energy Management of PV–Battery Based Microgrid System." *Procedia Technology* 21, pp. 103-111., (2015)

[2] Swaminathan Ganesan, Ramesh V, Umashankar S, "Performance Improvement of Micro Grid Energy Management System using Interleaved Boost Converter and P&O MPPT Technique", *International Journal of Renewable Energy Research*, Vol.6, No.2, pp.663-671, (2016)

[3] Bin Wu, Kouro, Samir, Mariusz Malinowski, Josep Pou, Leopoldo G. Franquelo, K. Gopakumar, Jose Rodriguez, "Recent advancement in industrial application of multilevel converter." *Industrial Electronic, IEEE Transactions* on 57, no. 8: pp. 2553-2580(2010)

[4] Kim, Sel-Ki, Jin-Hong Jeon, Chang-Hee Cho, Sae-Hyuk Kon. "Dynamic modeling and controls of a grid-connected hybrid generation system for versatile power transfers" *Industrial Electronics, IEEE Trans.* on 55, no. 4:pp. 1677-88. (2008)

[5] P.Sanjeevikumar, G.Grandi, Frede Blaabjerg, Patrick Wheeler, Olorunfemi Ojo, Pierluigi Siano, "A Comprehensive Analysis and Hardware Implementation of Control Strategies for High Output Voltage DC-DC Boost Power Converter", *International Journal of Computational Intelligence System (IJCIS)*, Atlantis Press and Taylor and Francis publications, Jun. 2016. (Accepted for publication).

[6] Hemanshu R, M.J. Hossain, M.A. Mahmud, Rajit Gadh, "Control for Microgrids with Inverter Connected Renewable energy Resources", *IEEE PES General Meeting, Washington DC, 27-31 July 2014*

[7] Sarina Adhikari, Fangxing Li, "Coordinated V-f and P-Q Control of Solar Photovoltaic Generators With MPPT and Battery Storage in Microgrids", *IEEE Transactions on Smart Grid*, Vol 5, No.3, May 2014

[8] Mao Yang, Hongping Li, "Analysis of Parallel Photovoltaic Inverters with Improved Droop Control Method", *International Conference on Modeling and Applied Mathematics (MSAM 2015)* - Published by Atlantis Press

[9] Swaminathan Ganesan, Ramesh V, Umashankar S, Sanjeevikumar P, "Fuzzy Based Micro Grid Energy Management System using Interleaved Boost Converter and Three Level NPC Inverter with Improved Grid Voltage Quality", *LNEE Springer Journal*, Dec-2016 (Accepted for Publication)

[10] Chitra Natesan, Senthil Kumar Ajithan, Swathi Chozhavendhan, Antiha Devendiran, "Power Management Strategies In Microgrid:A Survey", *International Journal of Renewable energy Research*, Vol.5, No.2, pp.334-340, (2015).

[11] Ashkan Nadimi, Farid Adabi, "Optimized Planning for Hybrid Microgrid in GridConnected Mode",

*International Journal of Renewable Energy Research, Vol.6, No.2, pp.494-503, (2016).*

- [12] Ramazan Bayindir, Eklas Hossain, Ersan Kabalci, Kazi Md Masum Billah, "Investigation on North American Microgrid Facility", *International Journal of Renewable energy Research, Vol.5, No.2, pp.558-574, (2015).*
- [13] Mangal Hemant Dhend; Rajan Hari Chile, "Fault diagnosis methodology in smart grid with distributed energy generation", *2016 IEEE International Conference on Renewable Energy Research and Applications (ICRERA), PP 885-890, (2016).*
- [14] Jeremy Every; Li Li; Youguang G. Guo; David G. Dorrell, "Maximizing investment value of small-scale PV in a smart grid environment", *2016 IEEE International Conference on Renewable Energy Research and Applications (ICRERA), PP 385-390, (2016).*
- [15] Hiroshi Awata; Toshiaki Yachi, "Electric power leveling of the microgrid system with PV power generation estimation and power demand estimation", *2016 IEEE International Conference on Renewable Energy Research and Applications (ICRERA), PP 353-357, (2016).*
- [16] Sneha Mane; Pratik Kadam; Gopal Lahoti; Faruk Kazi; N. M. Singh, "Optimal load balancing strategy for hybrid energy management system in DC microgrid with PV, fuel cell and battery storage", *2016 IEEE International Conference on Renewable Energy Research and Applications (ICRERA), PP 853-856, (2016).*