

# Autonomous Power System Powered by Solar Batteries: A Case of Box Oven Heating

N. El Moussaoui\*<sup>ID</sup>, A. Lamkaddem\*<sup>ID</sup>, M. Rhiat\*<sup>ID</sup>, K. Kassmi\*<sup>‡</sup><sup>ID</sup>, R. Malek\*<sup>ID</sup>,  
O. Deblecker\*\*<sup>ID</sup>, N. Bachiri\*\*\*<sup>ID</sup>

\* Department of Physics, Faculty of Science, Mohamed First University, Oujda, 60 000, Morocco

\*\* Electrical Power Engineering Unit, Faculty Polytech. Mons, University of Mons, Mons, 7000, Belgium

\*\*\* Association Humain and Environnement of Berkane (AHEB), Berkane, 63 300, Morocco.

(ndn.moussaoui@gmail.com, ali.lamkaddem@gmail.com, mohammed.rhiat@ump.ac.ma, khkassmi@yahoo.fr, rch\_malek@hotmail.com, Olivier.DEBLECKER@umons.ac.be, n\_bachiri@hotmail.com)

<sup>‡</sup>Corresponding Author; K. KASSMI, 60 000, Tel: +212 6 78 07 52 14,

Fax: +212 5 36 50 06 03, khkassmi@yahoo.fr k.kassmi@ump.ac.ma

*Received: 30.05.2022 Accepted:22.07.2022*

**Abstract-** In this paper, we present simulation and experimental results of an autonomous power system for supplying renewable energy applications with solar batteries. This system is based on the use of a multi-branch DC/DC Boost converter, where the power switches are controlled by a digital controller that generates a PWM signal of frequency 20 kHz and duty cycle  $\alpha$ . The electrical energy, produced by the photovoltaic (PV) panels, is stored in the batteries (24V, 520Ah) and then transferred to the load through the DC/DC converter. The experimental results obtained in the case of heating a solar cooker (oven box), heated by two thermal resistors of 15  $\Omega$ , using a DC/DC Boost converter, with three branches, show an electrical power of 300 W and duty cycle =0.7: currents of the branches of 5.3A, voltage and current of the battery of 21.82 V and 15.9 A, output of a DC/DC Boost converter of 70.4 V and 4.2 A. Under these conditions, the efficiency of the DC/DC converter is about 90 %, the energy supplied by the batteries is 558.33 Wh (i.e., 4.4 % of the battery charge), and the heating thermal resistors temperature reaches the value of 636°C after 5 minutes of heating, and the temperature inside the cooker 140°C after 40 minutes of heating. The comparison of all the results obtained with those simulated and those needed by users for cooking shows a very good agreement and consequently the validity of the functioning of the power system, of supply by solar batteries, proposed during this work.

**Keywords** Solar Batteries, Multi-branch DC/DC Boost, Solar Cooking, Oven Box,

## 1. Introduction

Solar photovoltaic power generation is the fastest growing source of energy production in the world [1,2]. This is a result of the significant reduction in the cost of solar photovoltaic energy over the past decade [3-6]. The energy produced by photovoltaic installations is stored in solar batteries to power various domestic applications (solar cookers, refrigerators, lighting, ...) [4-11]. However, these applications encounter problems with the adaptation of DC loads to solar batteries, and optimal operation of these loads

[7-9, 15, 16, 17-20]. Generally, in the literature, we find AC applications powered by solar batteries using DC/AC converters (inverters) [7,8]. This type of installation decreases the operating performance of the AC loads and presents a very excessive cost. In practice, in the case of DC load applications [12-20], there is a lack of work on systems that feed DC loads from batteries, through DC/DC converters, of the Boost or Buck type.

Several works [18-20] were carried out in the literature on solar ovens and cookers powered by solar energy. Currently, the existing solar cookers/ovens and most used are:

- The box-type solar PV cooker powered by a 60 Ah battery heats the water by 30°C to its boiling point of 100°C, after 105 minutes [18].
- Solar PV-T cooker is formed mainly by the photovoltaic panel and a parabolic reflector [19]. The concentrator makes it possible to concentrate the sun's rays and heat an absorbent plate placed inside the box oven. Electric heating is carried out by the direct supply of the cookers by the electrical energy stored in the batteries. The functioning of the cooker shows that the maximum temperature reached is of the order of 160 ° C during 4 h 10 min of operation,
- A PV cooker, consisting of two PV panels (460 W peak), two DC/DC converters type Boost, and thermal resistance of 14 Ω [20]. The operation of this cooker, under a maximum solar irradiance and ambient temperature of 730 W/m<sup>2</sup> and 24 ° C, shows temperatures of the heating resistance and that of the heated oil respectively of 580 ° C and 265 ° C, after 30 minutes of operation.

All of this work shows that in the literature there are very few applications that supply solar ovens with batteries. These applications do not use DC/DC converters controlled by PWM signals [20]. Consequently, the electrical power supplied to the ovens is very low and does not allow the ovens to be heated to a suitable cooking temperature (>100°C).

The objective of these works [10, 15, 18] is to carry out the cooking during the day and to store the surplus of electric energy in the batteries for the cooking, during the bad sunny periods and the nights [15-18]. These works [9, 13-20] show a total lack of DC power system (DC/DC converter) adapted to the heating of cookers (thermal resistances) by solar batteries.

In this context, we propose within the framework of national and international projects, the reliability of DC applications, powered by photovoltaic panels and solar batteries, using specific DC/DC converters. These realizations are adapted to each application (cookers, refrigerators, air conditioning, ...), according to the needs of the citizens.

In this work, we propose the design and the realization of a DC/DC converter, allowing the supply of solar cookers (oven box) by solar batteries. After having described the structure of this autonomous 300-400 W power system, we analyse the sizing of the three-branch Boost type DC/DC converter, equipped with an electronic regulation and control block, allowing the heating of the type cookers boxes by solar batteries (24 V, 520 Ah). Then, we present the results of the simulation and experimentation of the proposed system. Particular attention is attached to:

- The electrical quantities (voltage, current, and power) of the proposed DC/DC converter, and thermal quantities (cooker heating), depending on the duty cycle of the PWM commands of the power switches, of the DC/DC converter,
- Transfers the maximum power supplied by the batteries to the thermal resistance of the cooker (oven box),

- Validation of the proposed technique for cooker heating applications.

## 2. Structure and Operation of the Power System Powered by Solar Batteries

### 2.1. System Structure

Fig. 1 represents the synoptic diagram of the autonomous system, making it possible to supply a DC load by the solar batteries and a DC/DC converter of the multi-branch Boost type. As part of our work, the load is an application of renewable energies with a power of 400 W, formed by a box-type solar cooker, heated by two thermal resistors. The different blocks of this system are made up of the following equipment:

- ✓ Photovoltaic panels (400 W) whose role is to supply electrical energy and store it in the solar batteries, via a charge/discharge regulator.
- ✓ Solar batteries (24 V/520 Ah) which supply electrical energy to the multi-branch DC/DC Boost converter.
- ✓ Boost-type DC/DC converter with three branches (Fig. 2), for which the power switches are controlled by three identical PWM signals, with frequencies of 20 kHz and duty cycles  $\alpha$ . The role of this BOOST converter is to raise the 24 V DC voltage of the battery to a DC voltage of 67 V, under a power of 400 W.
- ✓ PWM control block generates 3 PWM signals to operate the three power switches (T1, T2, T3) of the DC/DC Boost converter in non-linear mode [20]. It is formed by a 'Raspberry Pi Pico' microcontroller and analog and digital components, passive and active. All active components used are biased by 5 V and 12 V voltages, from the solar battery.
- ✓ Application, formed by a cooker (Oven box) heated by two thermal resistances, supporting a temperature of 1400°C and a power of 600 W. These resistances are characterized by a longer lifespan (more than 15 years).

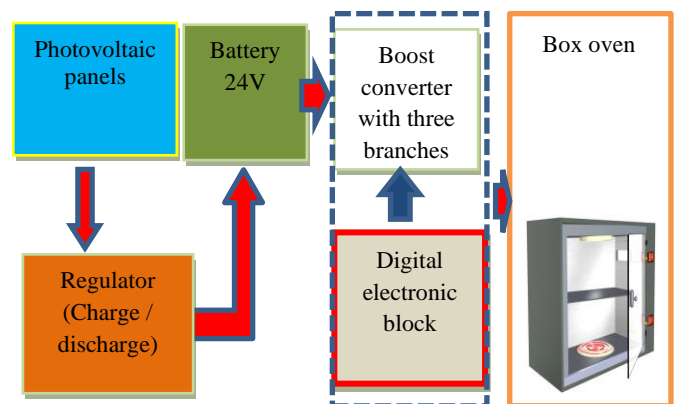

Fig. 1: Synoptic diagram of the autonomous system, allowing a DC load to be supplied by the solar batteries and a DC/DC converter of the multistage Boost type.

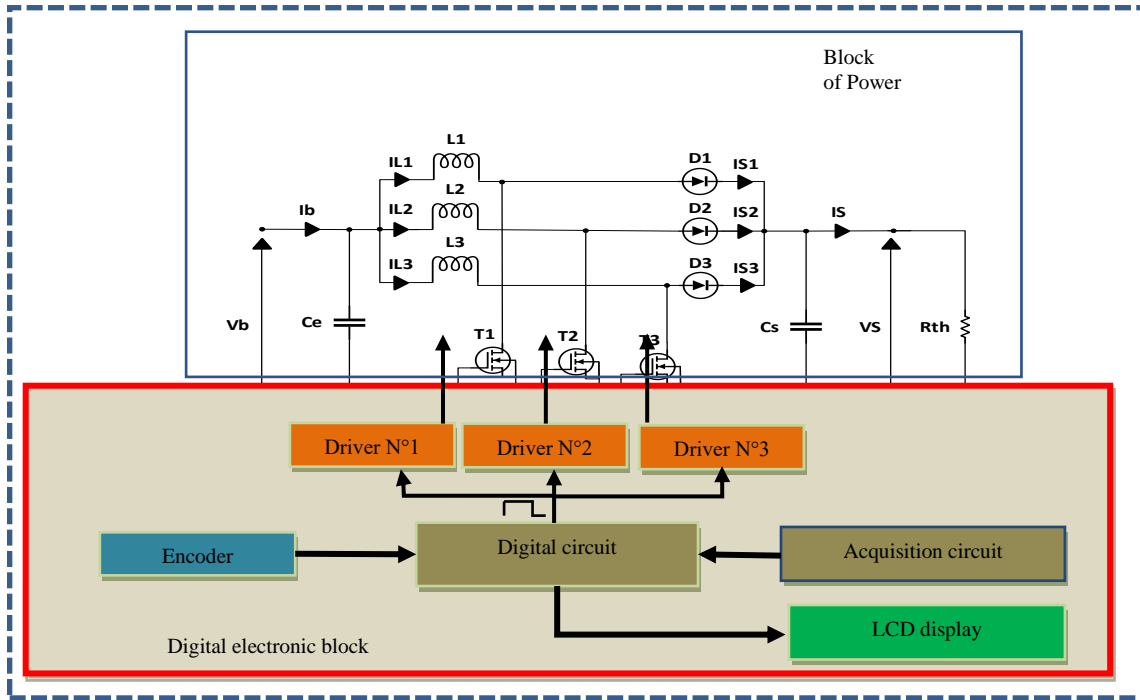

Fig. 2: Structure of the three-branches DC/DC converter and its control.

2.2. Dimensioning and Operation of the DC/DC Converter

The objective of the work carried out in our projects is to propose a power supply system for DC projects, by solar batteries (24V/520 Ah) at a power of 500-600 W. To do this, the DC/DC converter (Fig. 2) is dimensioned to operate at a frequency of 20 kHz, a current  $I_B = 15$  A, a current ripple in the inductors  $\Delta I_L = 5$  A, and voltage ripples at the input  $\Delta V_e = 1$  V and at the output  $\Delta V_S = 2$  V. Under these conditions, we use power switches of the MOSFET type, Inductors of each branch of 100  $\mu$ H, Input capacity of 1000  $\mu$ F, and output capacitance of 1000 $\mu$ F.

Furthermore, for each branch of this DC/DC converter (Fig. 2), the average of the electrical output values ( $V_s$ ,  $I_{Si}$ ,  $i=1,2,3$ ) and input ( $V_e$ ,  $I_{Li}$ ,  $i=1,2,3$ ), as well as the ripple of the current ( $\Delta I_{Li}$ ) and of the voltages at the output and at the input ( $\Delta V_e$ ,  $\Delta V_S$ ), obey the following equations [20-22] :

$$\frac{V_s}{V_e} = \frac{1}{1-\alpha} \tag{1}$$

$$\frac{I_{Si}}{I_{Li}} = (1-\alpha) \tag{2}$$

$$\Delta I_{Li} = \frac{\alpha \cdot V_e}{L \cdot f} \tag{3}$$

$$\Delta V_S = \frac{I_S - (0,5-\alpha)}{C_S \cdot f} = \frac{V_S - (0,5-\alpha)}{(1-\alpha) \cdot R_{Therm} \cdot C_S \cdot f} \tag{4}$$

Since,

$$I_{Bat} = I_{L1} + I_{L2} + I_{L3} = 3I_{Li} \text{ and } I_{Bat} = \frac{V_{Bat}}{R_{Bat}} \tag{5}$$

We can deduce,

$$I_{Bat} = 3 \frac{I_{Si}}{(1-\alpha)} \tag{6}$$

$$I_S = I_{Bat} (1-\alpha) \tag{7}$$

$$R_{Bat} = (1-\alpha)^2 R_{Thermique} \tag{8}$$

3. Simulation Results

The proposed system of the DC/DC converter and these control blocks of Fig. 2 are implemented in the Pspice simulator in order to follow the operation of the DC/DC converter and to record the electrical quantities (voltage, current, and power) at the input and at the output of this converter. In this paragraph, we present the typical simulation results obtained.

3.1. Operation as a Function of Thermal Resistance and Duty Cycle.

In Fig. 3 we have plotted the different electrical quantities (Fig. 2) at the input ( $I_{Bat}$ ,  $P_{Bb}$ ) and at and output ( $V_s$ ,  $I_s$ ,  $P_s$ ) and the efficiency of the DC/DC converter as a function of the duty cycle  $\alpha$ , for different values of the load (5  $\Omega$ , 10  $\Omega$ , 15  $\Omega$ , 20  $\Omega$ , 25  $\Omega$ ). The battery voltage is constant and of the order of 24 V. The overall results obtained show:

- ✓ For a duty cycle varies from 0.1 to 0.3, when the resistor varies from 5  $\Omega$  to 25  $\Omega$ , the currents in the branches (inductances) are 3.16 A, the voltages and output powers are 33 V and 220 W, whose maximum efficiency is of the order of 98% is obtained for a duty cycle of 0.1 .
- ✓ From a duty cycle of 0.5, the currents of the branches and power at the input and output increase. In the case of a resistance of 5  $\Omega$  and a duty cycle of 0.5, they are 6.16 A, 443.52 W, and 428.28 W, i.e. efficiency of 97 %.
- ✓ When the duty cycle varies from 0.4 to 0.5, in the case of a 15  $\Omega$  resistor, the currents in the branches (inductors) vary from 1.43 A to 2.10 A, the output voltages and powers vary from 38.95 V to 46.84 V, and 99.71 W to 144.27, the input power varies from 102.96 W to 151.20 W, i.e. a maximum efficiency of 95 %.
- ✓ In the case of a duty cycle of 0.7 and a resistance of 15  $\Omega$ :
  - The currents in the branches and output of the DC/DC converter are respectively 5.06 A and 4.8 A.
  - The output voltage and current of the DC/DC Converter are around 73 V and 4.8 A.
  - The input and output powers are of the order of 364.5W and 350.4 W, i.e. efficiency of the order of 96 %.

The analysis of these simulation results allows us to conclude that for our power application, which allows heating a cooker (oven box with 15  $\Omega$  thermal resistance) at a heating power of 350 W, the duty cycle of the PWM signals of the DC/DC converter DC is of the order of  $\alpha=0.7$ . Under these conditions, the input and output currents and voltage, and efficiency of the DC/DC converter are respectively of the order of 15.19 A, 24 V, 4.8 A, 73 V, and 96 %.

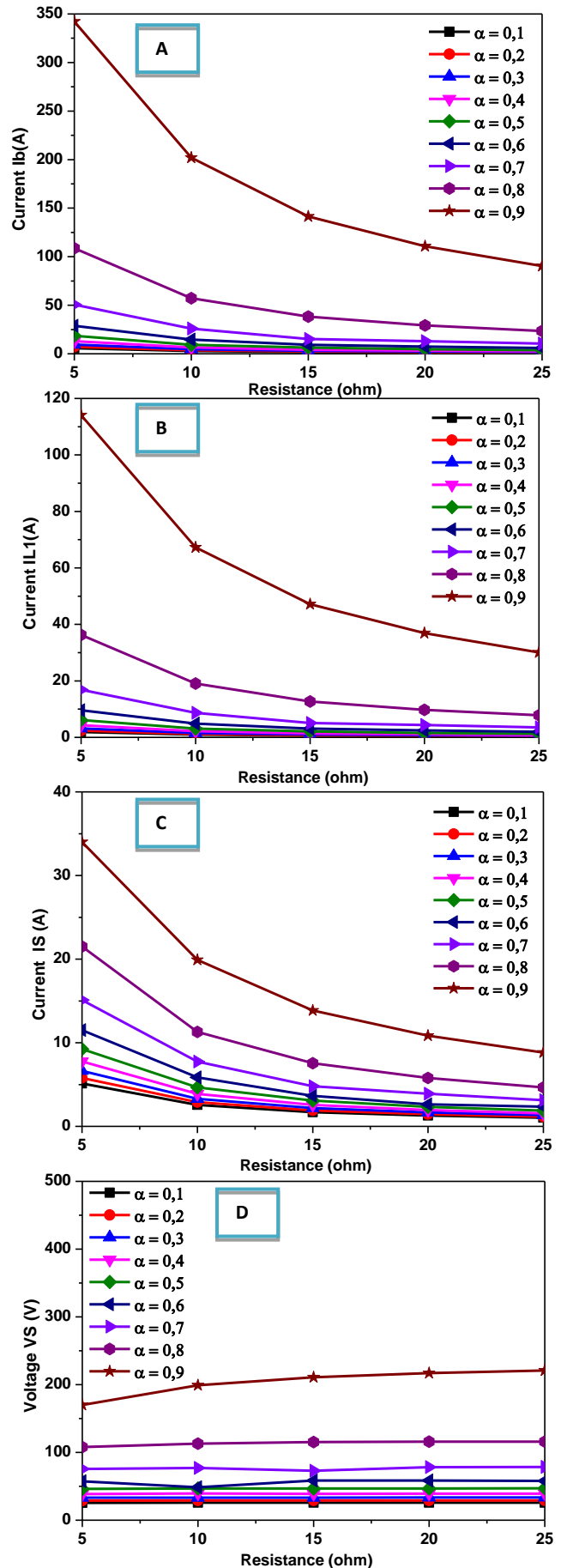

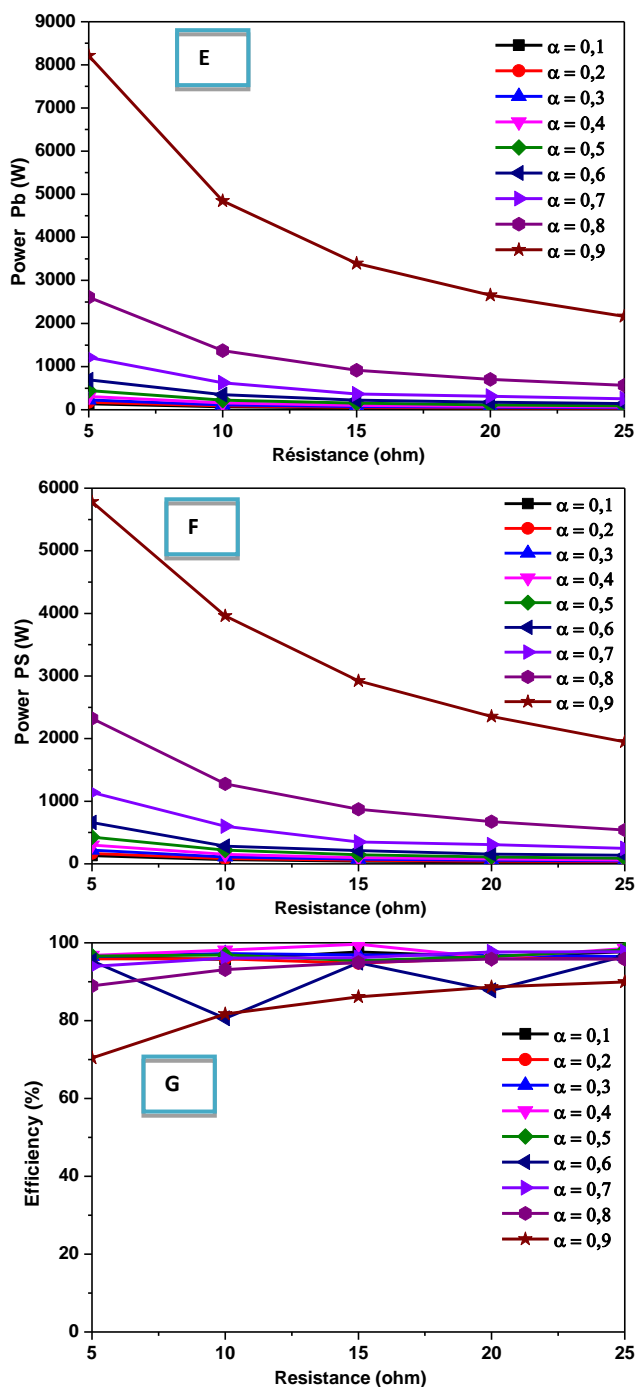

**Fig. 3:** Variation of electrical quantities as a function of the resistance  $R_{ch}$ .

- A: Variation of currents  $I_{Bat}$ ,
- B: Variation of currents  $I_{L1}$ ,
- C: Variation of  $I_S$  currents,
- D: Variation of voltage  $V_S$ ,
- E: Variation of Power  $P_B$ ,
- F: Variation of Power  $P_S$ ,
- G: Efficiency variation.

#### 4. Experimentation of the Multi-branch DC/DC Converter Powered by Batteries

##### 4.1. Experimental Procedure

Fig. 4 represents the power system, allowing the supply of a DC load to a solar battery by a multibranch DC/DC converter, and the measurement bench set up to characterize this system. As shown in Fig. 4, we used the following equipment:

- ✓ photovoltaic panels (400 W), whose role is to supply electrical energy and store it in the solar batteries, via a charge/discharge regulator,
- ✓ A solar battery 24V/520 Ah, whose role is to supply the DC/DC converter of the multi-branch Boost type, with a continuous voltage of 24 V and variable currents of intensity less than 30 A, depending on the value of the thermal resistance  $R_{Therm}$  of the application (Oven box),
- ✓ A DC/DC Boost converter, with three identical branches and input and output capacitors ( $C_e=1000 \mu F$  and  $C_s= 1000 \mu F$ ). Each branch is formed by an inductance ( $L= 100 \mu H$ ), switches (MOSFET IRF540N), and a fast diode (Schottky). This structure makes it possible to limit the strong currents which circulate in the inductors following the strong current delivered by the battery. This converter is sized so that it operates at a power of 300 W, in continuous mode, at a frequency of 20 kHz, input voltage of 24 V, output voltage  $V_s$  of 70 V, output current  $I_s=5$  A, inductance current ripples  $\Delta i_L=1.5A$  [20].
- ✓ A digital control of the DC/DC converter, which provides three identical PWM signals to control the three switches (T1, T2, and T3) in non-linear mode, by a PWM signal with a frequency of 20 kHz and a duty cycle  $\alpha=0.7$ . This command is based on the use of the Microcontroller 'Raspberry Pi Pico' and a block of three IR2111 drivers, to adapt the PWM signals and the input of the power switches.
- ✓ Load formed by cooker (Oven box, dimension: 64cm:43cm:36cm), heated by two thermal resistances, supporting a temperature of 1400°C, a power of 600 W.

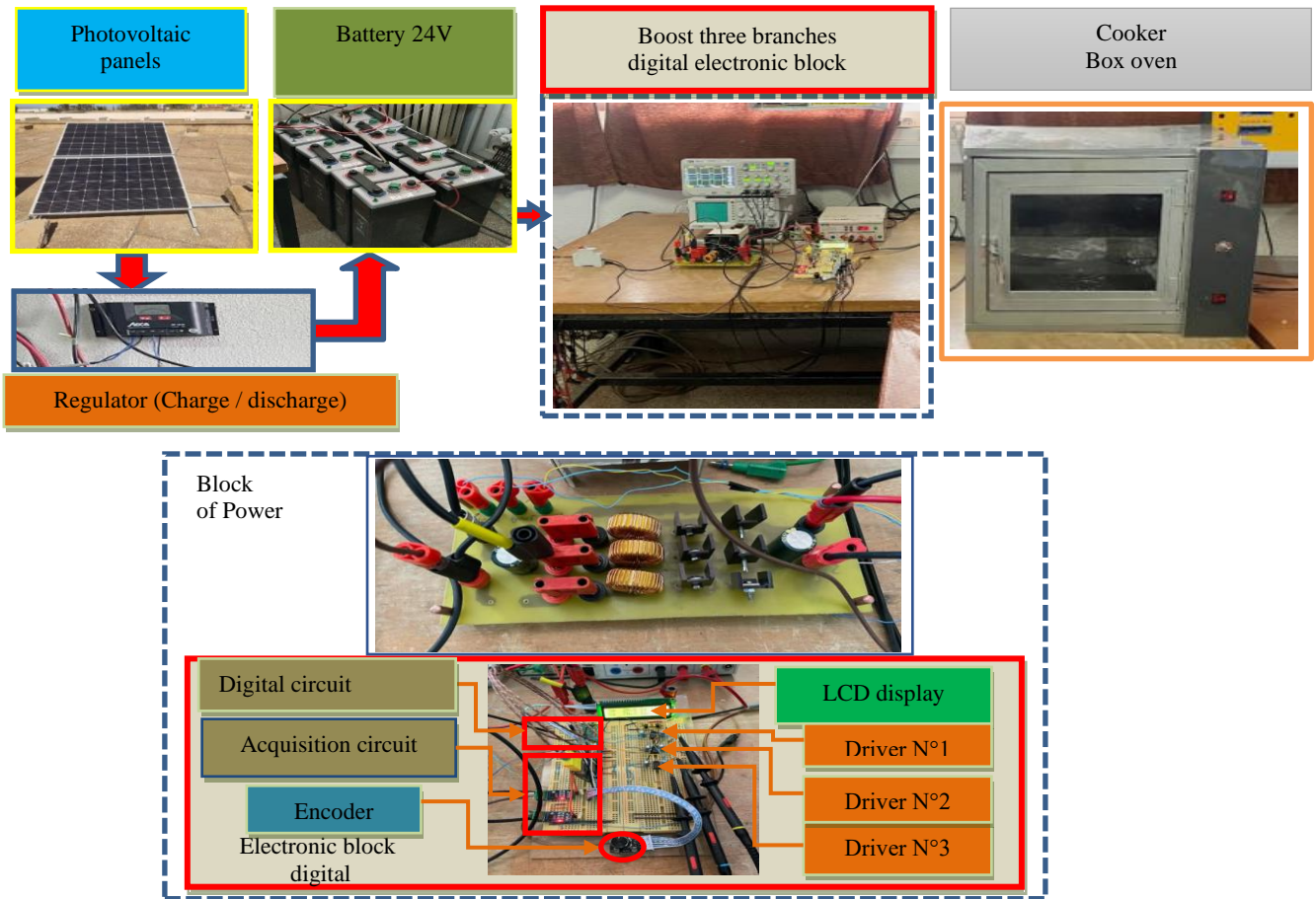

**Fig. 4:** Power system proposed in this work (Fig. 1) and measurement bench allowing the test of the system.

4.2. Experimental Results

4.2.1. Operation of the Multi-branch DC/DC Converter

In order to validate experimentally the DC/DC converter powered by the solar battery (24V/520Ah), for a load (15 Ω heating resistor), we noted the different electrical quantities (currents ( $I_{L1}$ ,  $I_B$ ,  $I_S$ ), voltages outputs ( $V_B$  and  $V_S$ ), power, efficiency) depending on the duty cycle  $\alpha$ , which varies from 0.1 to 0.7. On the same plots, we reported the simulation results. Typical results obtained, shown in Fig. 5, show as the duty cycle increase:

- ✓ When the duty cycle varies from 0.1 to 0.3, the currents in the branches (inductors) vary from 0.6 A to 1.03 A, the output voltages and powers vary from 25.86 V to 33.02 V and from 41.37 W to 66.04 W and a power input varies from 44.73 W to 75.33 W, i.e. a maximum efficiency of 92 %,
- ✓ From a duty cycle of 0.4 the currents of the branches and power at the input and output increase in a remarkable way. In the case of a resistance of 15 Ω, they are of the order of 1.43 A, 102.44 W, and 87.07 W, i.e. efficiency of 84 %.
- ✓ When the duty cycle varies from 0.5 to 0.6, in the case of a 15 Ω resistor, the currents in the branches (inductors)

vary from 2 to 2.96 A, the output voltages and powers vary from 43.99 V to 52.09 V and from 118.77 W to 161.29 W, an input power varies from 138.36 W to 195.18 W, i.e. a maximum efficiency of 85 %.

- ✓ When the duty cycle  $\alpha=0.7$ :
  - The voltages and currents at the input of the converter are respectively of the order of 21.82 V, 15.9 A, and at the output of the order of 70.4 V and 4.2 A.
  - The power at the input and output of the DC/DC converter are respectively of the order of 346.93 W and 295.68 W, i.e. efficiency of 85.2 %, The maximum temperature of the heating resistor is around 640°C.
- ✓ A very good agreement between the experimental results and those obtained by the simulation.

The experimental results obtained in this section show better performance of the proposed power system (Fig. 1) for a duty cycle of 0.7. Under these conditions, the power of the system of 300 W is in accordance with our specifications the temperature that feeds the thermal resistor at a temperature of 640°C. The good agreement between the experimental and simulated results of paragraph III shows the good operation of the three-branch DC/DC converter (Fig. 4) proposed in this work.

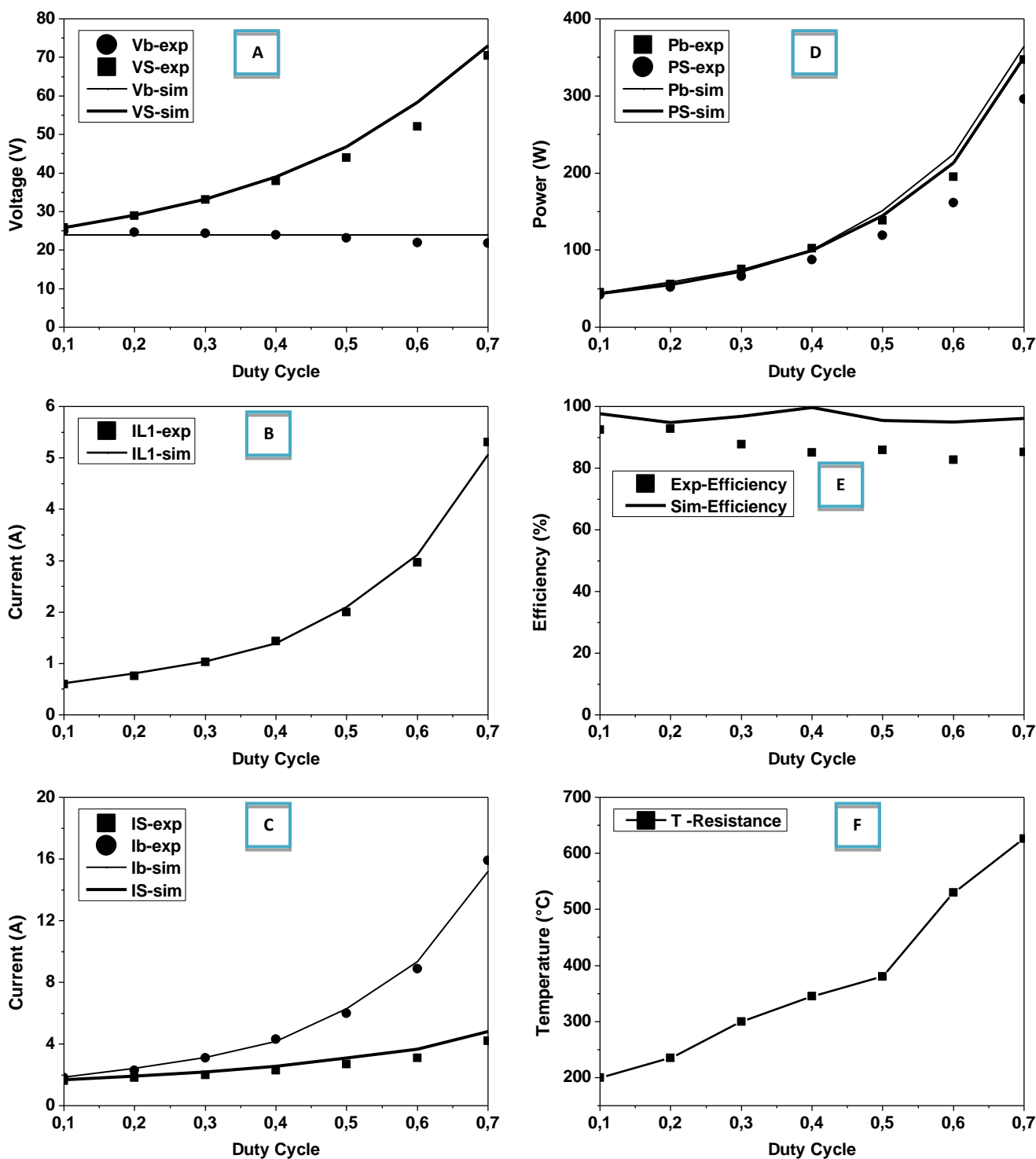

Fig. 5 : Variation of electrical quantities as a function of duty cycle  $\alpha$ .

- A: Variation of voltages  $V_B$ ,  $V_S$ ,
- B: Variation of  $I_{L1}$  currents,
- C: Variation of currents  $I_B$ ,  $I_S$ ,
- D: Variation of powers  $P_B$  and  $P_S$ ,
- E: Variation of efficiency,
- F : Variation of resistors temperatures.

4.2.2. Application Powering a 'Box Oven' Cooker

In order to validate the operation of the power system (Fig. 4), we experimented with the supply of a cooker (Oven Box) by the battery (24V, 520 Ah) and the three branches DC/DC converter, designed during this work (Fig. 6), for a duty cycle  $\alpha=0.7$ . We noted, as previously, the various electrical quantities at the input and output of the DC/DC converter as well as the heating temperatures of the two thermal resistors used, and those in the box Oven. The results obtained show:

- o The voltages and currents at the input of the converter are respectively around 21 V and 15.9 A, and at the output around 66.8 V and 4.3 A.
- o The power at the input and output of the converter are respectively of the order of 287.24 W and 333.9 W, i.e. efficiency of 86%.
- o The maximum temperature of the thermal resistance is of the order of 618°C and those of level inside the oven vary respectively from bottom to top from 130°C to 142°C.
- o The electrical energy supplied by the battery and that of the heating are respectively of the order of 648.34 Wh and 558.33 Wh.
- o The capacity of the battery consumed during this heating is of the order of 27 Ah (i.e. a reduction of 4 % in the level of charge or in the total electrical energy of the battery).

In terms of power and performance of the system, the results obtained during this box oven heating test experiment confirm the results obtained during simulation, and on the other hand, show the best performance of the proposed system for a duty cycle of 0.7. The obtained temperature of thermal resistors and in the ovens are 618°C and 140°C for the power of 300 W. These temperatures are very satisfactory for such cooking (bread, meat, chicken, etc.), and show the feasibility and proper functioning of the proposed standalone system (Fig. 4), based on the three-branches DC/DC converter Boost, to cooking with solar batteries.

The results obtained on this proposed system are very encouraging when compared to those obtained in the literature for photovoltaic energy [20, 22]. The proposed DC/DC converter and its digital control make it possible to supply the solar ovens with current levels, and therefore electrical power suitable for the solar box (>100°C). In addition, the good efficiency of the proposed DC/DC converter (> 90%) testifies to the feasibility of the proposed technique and its integration into a photovoltaic system for heating autonomous solar ovens with photovoltaic energy.

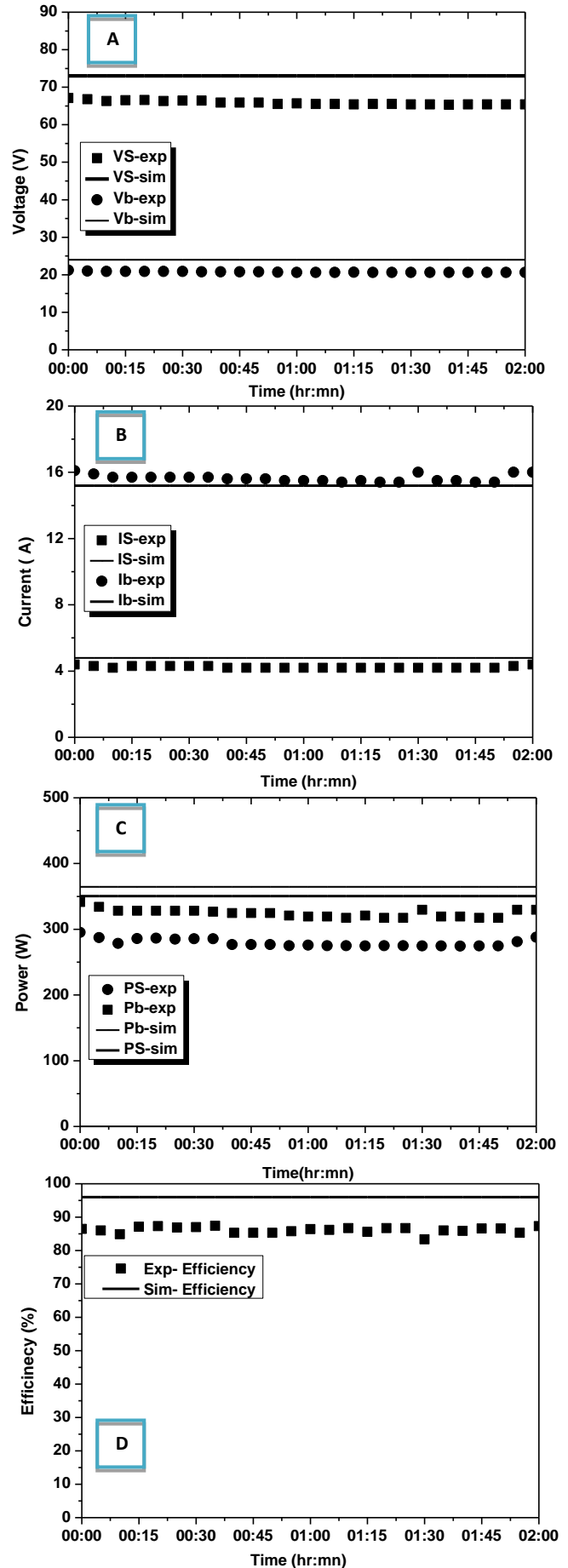



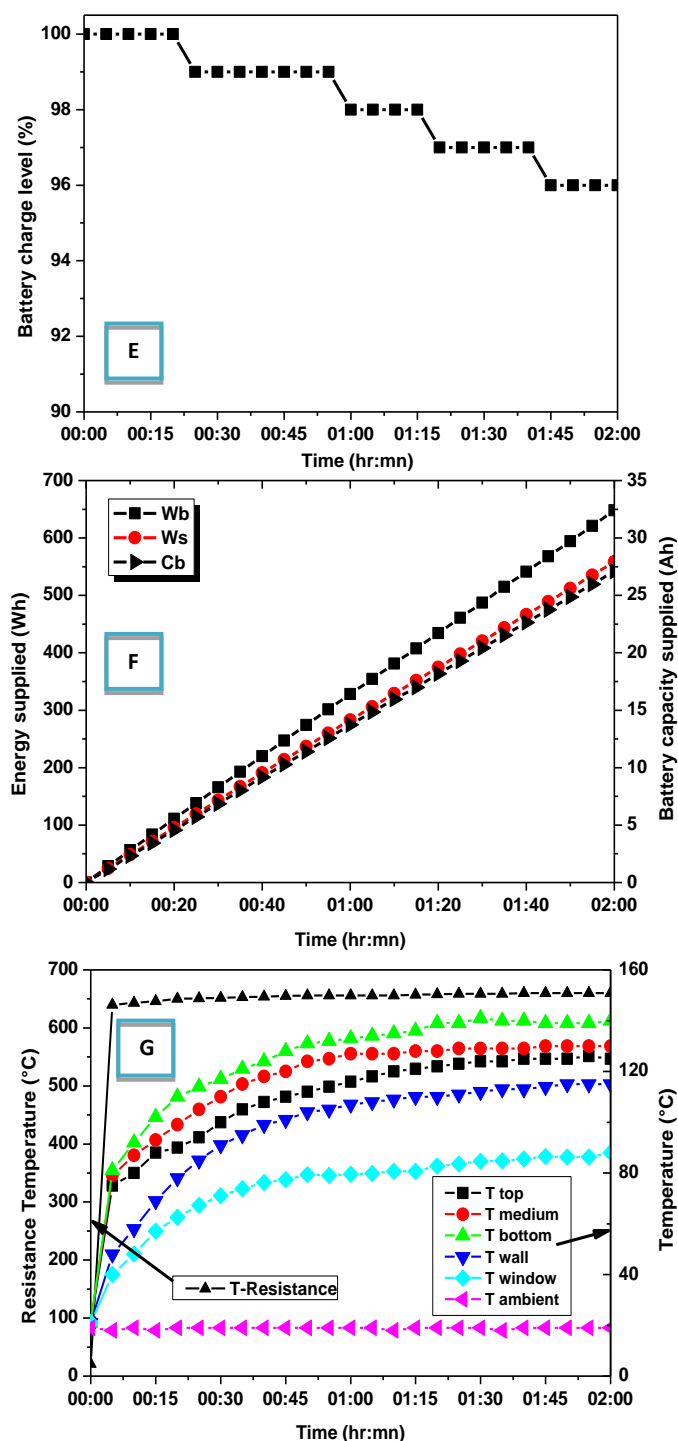

**Fig. 6 :** Electrical quantities, experimental and simulated (A to D), at the input and at the output of the complete system.  
 A- Input and output voltage,  
 B- Current at the input and at the output,  
 C- Converter input and output power,  
 D- Efficiency of the converter,  
 E- Battery level,  
 F- Energy supplied by the batteries, energy consumed by the thermal resistance during heating and Capacity supplied by the batteries,  
 G- Oven temperatures (Top and medium).

### 5. Conclusion

In this paper, we presented the results of simulation and experimentation of a new technique for powering solar cookers with batteries (24V DC, 520Ah). This is based on the use of the three-branch BOOST DC/DC converter, controlled by three PWM signals with a frequency of 20 kHz and a duty cycle of 0.7. The results obtained show:

- From the system simulation results, depending on the duty cycle and the load, heating power of 350W is obtained for a duty cycle  $\alpha=0.7$  and a load of  $15\Omega$ . Under these conditions, the output power is 350.4 W and therefore efficiency of 96%.
- From the experimentation of the system for a duty cycle of  $\alpha=0.7$ , voltages and currents at the input of the converter of 21.82 V, 15.9 A, the output of 70.4 V and 4.2 A, and the power at the input and output of the converter of 346.93 W and 295.68 W. The efficiency of the power system is therefore of the order of 85.2 %,
- Experimentation of the DC Four box type application, for a duty cycle of 0.7, input and output voltages of 21 V and 66.8 V, input and output powers of 333.9 W and 287.24 W, resistance and mid-furnace temperatures of 640°C and 140°C. During operation, the efficiency of the DC/DC converter is 86-90% and the energy supplied by the batteries for heating is 558.33 Wh (i.e., 4.4% of the total battery charge).

All the results obtained show a very good agreement between the simulation and the experiment, remarkable performance for a duty cycle of 0.7, where the efficiency of the proposed DC/DC converter is about 90%, oven heating temperature of 140°C, and the electric energy consumed during the heating of 4.4 % of batteries. These performances show both the proper functioning of the proposed power system and the DC application of heating by the solar batteries.

### Acknowledgements

This research is supported within the framework of the projects:

- Morocco-Wallonie Brussels Cooperation Program (2018-2022), Wallonie-Bruxelles-International (Belgium), project 4, n<sup>o</sup>2,
- Europe-Africa Research and Innovation call on Renewable Energy LEAP-RE, Project No 963530: SoCoNexGen, Solar Indoor Cooking Systems of the Next Generation, 2022-2025
- National Initiative for Human Development INDH, Berkane Province, Morocco, project 2017//29.

### References

[1] A. Ndiaye and M. Faye, "Experimental Validation of PSO and Neuro-Fuzzy Soft-Computing Methods for Power Optimization of PV installations," in 2020 8th International Conference on Smart Grid (icSmartGrid), 2020, pp. 189-197: IEEE.

- [2] M. Caruso, R. Miceli, P. Romano, E. R Sanseverino, G. Schettino, F. Viola, and T. N Ngoc, "Comparison between different dynamic reconfigurations of electrical connections for partially shaded PV modules," in 2018 International Conference on Smart Grid (icSmartGrid), 2018, pp. 220-227: IEEE.
- [3] N. Güler and E. Irmak, "MPPT based model predictive control of grid connected inverter for PV systems", International Conference on Renewable Energy Research and Applications (ICRERA), pp. 982-986, 2019
- [4] A. Allik, H. Lill, and A. Annuk, "Effects of Price Developments on Photovoltaic Panel to Inverter Power Ratios", 8th International Conference on Renewable Energy Research and Applications (ICRERA), pp. 371-376, 2019.
- [5] E. P. Wiechmann, J. Henriquez, P. Aqueveque, J. Díaz, A. Morales, and C. Manriquez, "Taking advantage of PV energy in copper electrowinning requires a trend reversal: Increasing inter-electrodes spacing", 7th International Conference on Renewable Energy Research and Applications (ICRERA), pp. 748-752, 2018
- [6] I. K. Almadani, I. S. Osman, N. G. Hariri, M. Saleem, and N. A. Hassanain, "Investigating the Effects of Solar Tracking Systems on Thermal Profile of Photovoltaic Modules, " International Journal of Renewable Energy Research, vol. 11, no. 4, pp. 1561-1569, 2021.
- [7] M. Ouali, M. A. Djebiret, R. Ouali, M. Mokrane, N. K. Merzouk, and A. Bouabdallah, "Thermal control influence on energy efficiency in domestic refrigerator powered by photovoltaic", International Journal of Hydrogen Energy, Vol. 42, No. 13, pp. 8955-8961, 2017.
- [8] B. L. Gupta, M. Bhatnagar, and J. Mathur, "Optimum sizing of PV panel, battery capacity and insulation thickness for a photovoltaic operated domestic refrigerator", Sustainable Energy Technologies and Assessments, Vol. 7, pp. 55-67, 2014.
- [9] N. El Moussaoui, K. Kassmi, S. Alexopoulos, K. Schwarzer, H. Chayeb, and N. Bachiri, "Simulation studies on a new innovative design of a hybrid solar distiller MSDH alimented with a thermal and photovoltaic energy", Materials Today: Proceedings, Vol. 45, pp. 7653-7660, 2021,
- [10] J. Singh and P. Singh, "Solar Electric Cookstove-A First Generation, High Efficiency Solar Electric Cooking Device Prototype", in 2019 IEEE Global Humanitarian Technology Conference (GHTC),: IEEE, pp. 1-6, 2019.
- [11] T. Watkins, P. Arroyo, R. Perry, R. Wang, O. Arriaga, M. Fleming, C. O'Day, I. Stone, J. Sekerak and D. Mast, "Insulated Solar Electric Cooking–Tomorrow's healthy affordable stoves? ", Development Engineering, vol. 2, pp. 47-52, 2017.
- [12] Akter, M. Haque, M. Masrur, and S. F. Ahmed, "Performance and testing of the improved solar electric cooking system", Brac University, 2019
- [13] P. K. Devan, C. Bibin, S. Gowtham, G. Hariharan, and R. Hariharan, "A comprehensive review on solar cooker with sun tracking system", Materials Today: Proceedings, vol. 33, pp. 771-777, 2020
- [14] O. Kaptिंग'ei, M. Muchuka, and D. Nyaanga, "advances in solar cooking in developing countries-a review," 2021.
- [15] Batchelor, E. Brown, J. Leary, N. Scott, A. Alsop, and M. Leach, "Solar electric cooking in Africa: Where will the transition happen first? ", Energy Research & Social Science, vol. 40, pp. 257-272, 2018
- [16] S. Batchelor, A.R. Talukder, R. Uddin., S. K. Mondal, S. Islam, R. K. Redoyet, R. Hanlin and M. R Khan, "Solar e-cooking: A proposition for solar home system integrated clean cooking", Vol. 11, No. 11, p. 2933, 2018.
- [17] E. R. A. Larico, "Photovoltaic solar cooker controlled by pulse width modulation in the Peruvian highlands", in 2021 IEEE PES/IAS Power Africa, 2021: IEEE, pp. 1-5.
- [18] OSEI, Emmanuel Yeboah and AMO-AIDOO, Araba. "Design, Fabrication, and Testing of a Solar Photovoltaic Cooker in Ghana", International Conference on Applied Science and Technology Conference Proceedings. pp. 182-188, 2018.
- [19] S. Attyaoui, C. Ali, K. Rabhi, F. Nasri, and H. Bacha, "Experimental Investigation and Modelling of a PV/T Solar Cooker", p. 1632, 2012.
- [20] I. Atmane, N. El Moussaoui, K. Kassmi, O. Deblecker, and N. Bachiri, "DEVELOPMENT OF AN INNOVATIVE COOKER (HOT PLATE) WITH PHOTOVOLTAIC SOLAR ENERGY," Journal of Energy Storage", Vol. 36, p. 102399, 2021.
- [21] S. Talbi, I. Atmane, N. El moussaoui, K. Kassmi, and O. Deblecker, "Feasibility of a box-type solar cooker powered by photovoltaic energy", in 2019 7th International Renewable and Sustainable Energy Conference (IRSEC), pp. 1-4, 2019
- [22] I. Atmane, N. El Moussaoui, K. Kassmi, O. Deblecker, and N. Bachiri, "Alternating multi-stage maximum power point tracking controlled parallelled photovoltaic systems for "solar cooker", International Journal of Circuit Theory Applications, Vol. 49, No. 11, pp. 3908-3921,2021