

Performance Enhancement by Novel Hybrid PV Array Without and With Bypass Diode Under Partial Shaded Conditions: An Experimental Study

Niti Agrawal*[†], Birinchi Bora **, Supriya Rai **, Avinashi Kapoor ***, Mridula Gupta***

* Department of Physics, Shyamlal College, University of Delhi, Delhi-110032, India

** National Institute of Solar Energy, Gurgaon 122003, India

*** Department of Electronic Science, University of Delhi South Campus, New Delhi- 110021, India
(nitichin@yahoo.co.in, birinchibora09@gmail.com, supriya.ece.imps@gmail.com, avinashi_kapoor@yahoo.com, mridula@south.du.ac.in)

[†] Corresponding Author; Niti Agrawal, Shyamlal College, University of Delhi, Delhi-110032, India,

Tel: +91 9810391961, nitichin@yahoo.co.in

Received: 10.09.2021 Accepted:04.10.2021

Abstract- Partial shading can significantly hamper the output performance of field installed PV arrays. In this study a procedure is reported to mitigate the adverse impact of partial shading on PV array and improve its efficiency by opting for a PV configuration which has the least susceptibility to partial shading losses and can produce maximum power. For this purpose, a new configuration of PV array (of size 145 Wp), which is a hybrid of total-cross-tied and series (TCT-S), has been designed and studied. TCT-S array has series configuration at module level and total cross tied configuration at cell level. Experimental investigations in real field conditions have been conducted on the novel hybrid array without and with bypass diodes under unshaded and partial shaded conditions. The results have been compared with the conventional pure series configuration of PV array. Twelve distinct partial shading conditions, ranging from only a single shaded cell in the entire array to partially shading all the modules within the array have been considered for this work. The output power, power loss, utilization factor and power enhancement of the proposed configuration is investigated without and with bypass diode under the considered partial shading scenarios. The maximum enhancement achieved by proposed novel configuration of PV array in comparison to conventional array, is 55.4% and 62.8% without and with bypass diodes respectively. Moreover, it is also observed that in the absence of bypass diode, while the conventional array output power is dragged down to zero with only one cell failure, the proposed TCT-S array can still generate approx. 90% power.

Keywords Novel configuration, total cross tied, partial shading, power loss, hybrid array.

1. Introduction

Partial shading (PS) and its effect on photovoltaic system has received due attention as it is a commonly occurring condition for the field installed PV array which can

NOMENCLATURE

Abbreviations

significantly hamper its output performance [1-3]. Partial shading is a condition in which presence of any nearby structure, bird dropping, moving cloud or soiling etc. cast shadow on some area of installed PV panels due to which there is a mismatch in the level of irradiance among its

PSC partial shading condition

PV photovoltaic

BL bridge-linked

SP	series-parallel
SS	standard series
TCT	total-cross-tied
STC	standard test conditions
BIPV	building integrated photovoltaic
UF	utilization factor
PE	power enhancement
BPD	bypass diode

Symbols

n	diode ideality factor
---	-----------------------

I_o	reverse saturation current (A)
I_{ph}	photo generated current (A)
I_{sc}	short circuit current (A)
I_m	PV module current (A)
I_{array}	PV array current (A)
P_{max}	maximum power generated by the array under shaded condition (W)
R_s	series resistance of the cell (Ω)
R_{sh}	shunt resistance of the cell (Ω)
V	PV cell voltage (V)
V_m	PV module voltage (V)
V_{array}	PV array voltage (V)
V_{th}	thermal voltage of solar cell (V)

I	PV cell current (A)
---	---------------------

cells/modules [4-7]. PSCs results in reduced efficiency of PV module and if prolonged can destruct the cells due to hot spots and reduce their lifetime. Hence, it has been motivating researchers to explore different methods and technique to alleviate the adverse effect of partial shading and to enhance the output power [8-13].

Altering interconnections of modules/cells in an array in different fashion (array configuration) is a fine strategy for maximizing power generation from partially shaded PV array. Various types of PV array configurations such as conventional configurations (series (S), parallel (P), series-parallel (SP), total cross tied (TCT), bridge linked (BL), honey comb (HC)), hybrid configurations, reconfigured and mathematical puzzle-based configurations have been tested/studied by the researchers over a period of time [14-29].

Matlab/Simulink based investigation of the performance of conventional configurations (S, P, SP, BL, TCT) of the PV array under partial shadow conditions have been conducted in ref [14-18]. Further the authors of ref [19] conducted a comparative performance investigation of SP, BL, HC, TCT and a novel configuration in real outdoor conditions. The results of these studies have shown that TCT configuration of PV array exhibits least mismatch losses and delivers maximum power under nearly all types of shading conditions. However, implementation of larger size TCT configured PV array needs to be examined in terms of complexity, installation time and cost. As large number of cross ties are present, therefore implementation of bigger size TCT configured array may become more complex, costly and need more time to install. Hybrid configurations i.e., combination of two configurations in a PV array have also been tested by some researchers. The authors of [20] compared the performance of SP, HC, TCT, BL and LD configurations with hybrid configuration like BLTCT (a combination of bridge-linked and total cross tied), SPTCT (a

combination of series-parallel and total cross tied), and BLHC (a combination of bridge-linked and honey-comb), under static and dynamic shading patterns. The results showed that TCT followed by BLHC is the optimum configuration under shading conditions. In ref. [21] authors presented a Matlab/Simulink based comparative performance analysis of conventional and hybrid configurations (SP-TCT, BL-TCT and HC-TCT) under partial shading conditions. The authors concluded that though TCT configuration exhibits the best performance under PSCs, the hybrid configurations are more economical than TCT configuration and also deliver satisfactory performance.

Reconfiguration techniques of PV arrays based on mathematical puzzles like sudoku puzzle and its variant, magic square etc. have also been proposed and examined in an attempt to increase the efficiency of partially shaded PV arrays [22-28]. The result of these studies show that reconfigured arrays have better efficacy in comparison to other configurations. However, reconfiguring by physically relocating the modules implies arduous interconnections, increase in complexity and line losses due to increases in interconnecting wires length.

In ref [29], the authors presented a technique of nullifying the mismatch losses under partial shading by connecting converters with each row of TCT PV array, which extract the mismatch power and store it in battery bank, which can feed the power to the grid during night time. Though the results show zero mismatch loss and decreased power loss, implementation of the proposed method requires additional circuit components which would escalate the system cost.

Although the above-mentioned mitigation strategies have their own advantages and disadvantages/limitations, still it is important to point out here an assumption made in all these works. A PV module rather than cell has been considered as the basic unit of PV array. Hence it is always

assumed that at any time all cells in a module receive same level of irradiance. This however is not generally true in real life situation especially in building integrated photovoltaic (BIPV) system and residential rooftop installed PV system. For such installations, shading from fallen leaf, bird litter, overhead transmission wire, nearby pole, chimney or any fixed object, self-shading between rows of PV modules etc. can shade only a few cells i.e., a portion of PV modules within the array. Therefore, for an extensive investigation/analysis of non-homogenously irradiated PV array it is important to consider cell level shading and its effect on PV array performance. Moreover, as seen from the literature most of the investigations for PV array configuration under different shading scenarios have been conducted in simulated environment. The results of simulated environment cannot be considered same as that of real field condition. Therefore, it is also required to conduct more of experimental investigations in real outdoor conditions, which at present are only few.

The brief literature survey highlights the following points:

1. Need for shading mitigation strategy which is easy to implement and doesn't escalate the cost of PV system.
2. Requirement of exhaustive study of partially shaded PV performance by considering shading phenomenon at cell level rather than module in real field conditions.

The authors in their previous work presented the concept of implementing different cell interconnections inside the module. An experimental study of performance of different configuration of PV modules (series, series-parallel, bridge-linked and total-cross-tied) of 50 Wp each was conducted [30]. It was found that TCT module has much better performance in comparison to other configurations under partial shading conditions. The study was conducted only on single module of each type. However, for most of the practical applications an array of modules is required to fulfil the power requirement. Therefore, extending our previous work, we present a novel configuration of PV array which is the hybrid of TCT and S configuration. It is called total-cross-tied in series or TCT-S configuration of the PV array. Pure series is the simplest configuration to implement but, because of low output current its application is limited. TCT configuration is the one which is most sustainable under partial shading conditions. However, its implementation may become complex and difficult for larger PV array size due to large installation wires. The proposed hybrid configuration aims to combine the advantages of both the configurations-ease of implement (S) and high performance under PSCs (TCT). TCT-S array is constituted by series connected PV modules but here each module inside has solar cells interconnected in total cross tied fashion. Moreover, the role of bypass diodes in such a hybrid configuration is also investigated.

For this research work, an array of TCT-S configuration of 145 Wp has been developed, investigated and compared with the conventional S-S array. By S-S configuration we mean a PV array composed of series connected module

having series connected solar cells inside. Experimental investigation on both types of arrays have been done in real operating conditions under unshaded and twelve partial shaded conditions. These partial shading scenarios widely range from only a single shaded cell in the entire array to shade partially covering all the modules within the array. The shadow conditions have been generated artificially by masking cells/modules with different sheets. The performance of the proposed configuration is investigated in terms of output power, power loss, utilization factor and power enhancement (defined in section 4.3) in the absence and presence of bypass diodes. The present study will help in understanding (i) cell level shading phenomena and its repercussions on the entire PV array's output performance. (ii) the behaviour of TCT-S array under different cell level shading scenarios in comparison to conventional array.

The insights provided by this study is of great significance for BIPV, rooftop PV system and any other installed PV system where partial shading of installed panels is commonly encountered. The proposed TCT-S array has less requirement of bypass diodes in comparison to the conventional configuration.

2. PV System Components

2.1 Modelling of PV cell

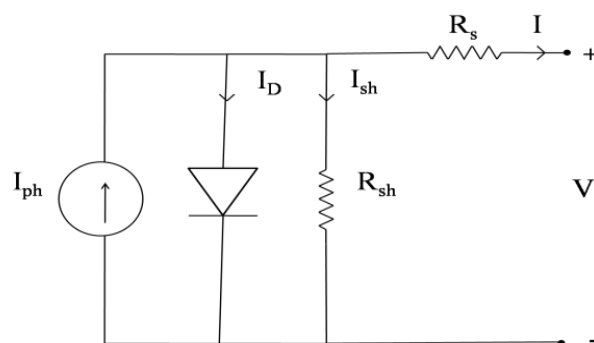

Fig. 1. Single diode model of a solar cell.

A solar cell is the fundamental unit of PV system, which is widely represented by the single diode model (Fig.1). The five parameters of the model are: I_{ph} , I_o , n , R_s and R_{sh} . Based on this model, the current-voltage characteristic of a PV cell is given by Eq.(1) [31,32].

$$I = I_{ph} - I_o \left[\exp\left(\frac{V + IR_s}{nV_{th}}\right) - 1 \right] - \frac{V + IR_s}{R_{sh}} \quad (1)$$

Power generated by a single PV cell is low (less than 2-3 Watt). To enhance the power output, cells are interconnected to form PV modules, which are further interconnected to form PV arrays.

2.2 PV array configuration

2.2.1 Standard series in series array (S-S Array)

S-S array is composed of ‘n’ standard series PV modules (S-module) connected in series as shown in Fig. 2.a. Standard series module is the one which is composed of 36 solar cells connected in series (Fig. 2.b). The current across all the cells inside is same, equal to module current (I_m). Module voltage (V_m) is the sum of the voltages of individual cells.

$$I_m = I_1 = I_2 = \dots = I_{36} \tag{2}$$

$$V_m = \sum_{i=1}^{36} V_i \tag{3}$$

PV modules are further interconnected in series, therefore current and voltage of S-S configured array can be written as:

$$I_{array} = I_1 = I_2 = \dots = I_n = I_m \tag{4}$$

$$V_{array} = \sum_{i=1}^n (V_m)_i \tag{5}$$

2.2.2 Total-cross-tied in series array (TCT-S array)

TCT-S array is formed by ‘n’ total -cross-tied modules (TCT-module) connected in series as shown in Fig. 2.c. TCT module is the one which is made up of 36 solar cells interconnected in TCT fashion i.e., ties are connected across each row of junction. Each row has 4 cells in connected in parallel. There are 9 such rows in total which are connected in series (Fig. 2.d).

The current and voltage equations for a single TCT-module is, obtained by applying KCL at the nodes, and is presented by Eq.(6) and (7) respectively.

$$\sum_{j=1}^4 (I_{i,j} - I_{i+1,j}) = 0, \quad i = 1, 2, 3, 4 \dots 9 \tag{6}$$

$$V_m = \sum_{r=1}^9 V_r \tag{7}$$

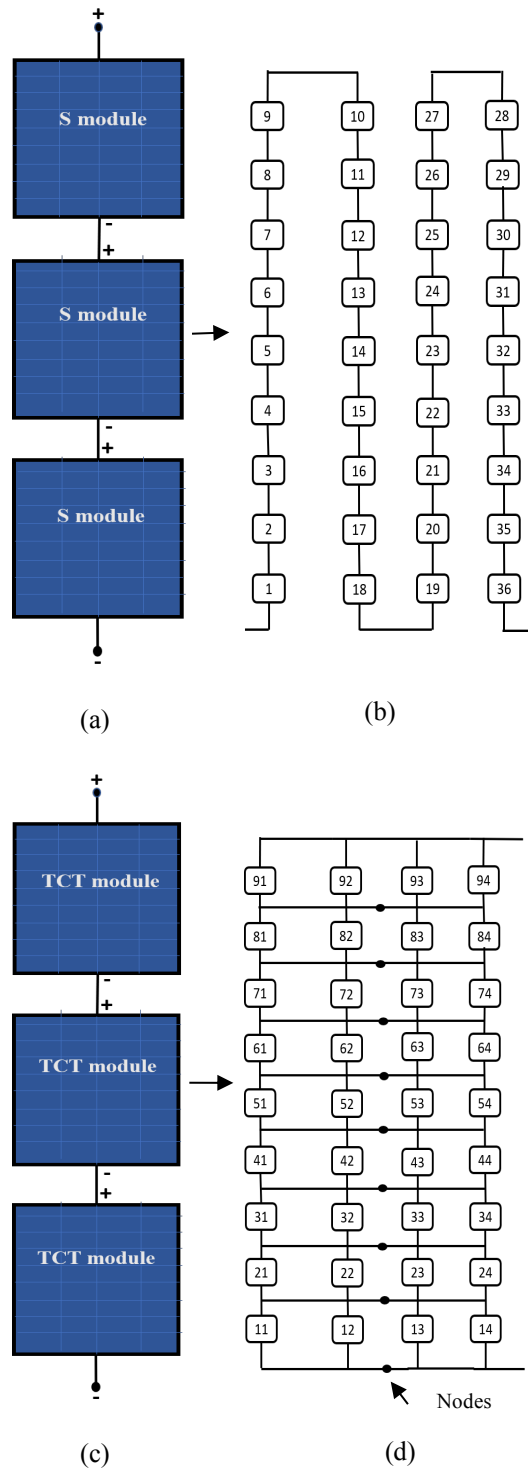

Fig. 2. Schematic of (a) S-S array (b) S-module cell interconnections (c) TCT-S array (d) TCT-module cell interconnections.

Table 1. Electrical parameters of S-module and TCT-module at STC.

Parameters	S-module	TCT-module
Maximum power rating [Wp]	49 Wp	48.5 Wp
Maximum power voltage (V _{mp})	19.21 V	4.48 V
Maximum power current (I _{mp})	2.55 A	10.81 A
Open circuit voltage (V _{oc})	23.06 V	5.76 V
Short circuit current (I _{sc})	2.72 A	11.66 A
No. of cells	36	36
Interconnection scheme of cells	Series	Total-cross-tied

Where, V_r represents to the voltage of the rth row consisting of four parallel connected cells.

TCT-modules are further interconnected in series, therefore current and voltage of TCT-S configured array can be written as:

$$I_{array} = I_1 = I_2 = \dots = I_n = I_m \tag{8}$$

$$V_{array} = \sum_{i=1}^n (V_m)_i \tag{9}$$

For the present work three S-modules and three TCT-modules have been used to construct S-S array and TCT-S array respectively of 145Wp. The electrical parameters of S-module and TCT- module used is given in Table 1.

Both S-modules and TCT-modules were procured from a certified and reputed PV manufacturer. While TCT-modules have been designed and manufactured especially for this research work, S-modules are commercially available.

2.3 Formation of artificial shading scenarios

The paper aims to compare the performance of the proposed configuration with the conventional PV array under different cell level shading conditions and understand the impact on array performance. For this, different shading scenarios have been generated artificially using sheets of paper. A shading pattern can be characterized on the basis its shape, size, distribution as well as shade strength. Shade strength of any shadow can range from 0% to 100%, and is found using Eq. (10).

$$Shade\ Strength = 1 - \frac{Irradiance\ received\ by\ PV\ cell\ (W/m^2)}{Irradiance\ at\ STC\ (1000\ W/m^2)} \tag{10}$$

Three different shade strengths, viz. 100%, 60%, 40% have been created for this work using sheets of paper.

2.4 Impact of Bypass diode

During partial shading, the unshaded PV modules operate at current levels higher than those of shaded PV module. As a consequence, the shaded cells in the module are forced into reverse bias and starts to dissipate power, with a consequent temperature increase termed as Hotspot. So, in order to avoid the destructive effect of the hotspot and to enhance the power output, bypass diodes are placed in parallel with a group of cells, but with opposite polarity. Bypass diodes conduct the extra current generated by the unshaded modules to prevent mismatching among modules, and hotspots.

TCT-S being a novel configuration with different interconnections and hence role of bypass diode on its output power is investigated under shadowed conditions.

3. Field Set Up

All the testing and measurements of the arrays have been done at National institute of Solar Energy (NISE), Gurgaon, Haryana (India). For the field measurements, both the arrays were put on fixed support structure facing south. The I-V measurements of the arrays have been done with Solmetric P-V Analyser (PVA-1000S) which is a portable test instrument. The details of the same is presented in author’s previous work [30]. The photograph of the experimental set up used is presented in Fig. 3.

4. Experimental Procedures



Fig. 3. Outdoor experimental setup used.



Fig. 4. One cell of the array shaded with 100% strength to mimic cell failure.

4.1 Outdoor investigations under partial shading conditions

Following investigations have been conducted on both the configurations of PV array:

4.1.1 Investigation under Shading Conditions Without Bypass Diode (Cell / Module Failure)

Under this investigation, one cell of the module within S-S and TCT-S array without bypass diodes has been completely shaded with 100% strength to mimic the effect of cell failure/damage (as shown in Fig. 4). By cell failure we mean any condition, which may or may not be permanent, because of which the cell is not able to generate any power. The shading is then extended to other cells till one row is completely shaded. The objective of this investigation is to look for the condition where TCT module fails to generate power in the absence of bypass diodes and to compare it with the S-module.

Case I : one cell or 25% of the row of the module shaded with 100% strength.

Case II : two cells or 50% of the row of the module shaded with 100% strength.

Case III : three cells or 75% of the row of the module shaded with 100% strength.

Case IV : four cells or 100% of the row of the module shaded with 100% strength.

4.1.2. Investigation under Various Random Partial Shading Conditions Without and With Bypass Diode

Under this investigation 12 diverse random shading patterns are created ranging from single shaded cell in the array to shade patterns extending over all the modules within the array. These shading patterns are inspired from the real-life situations like fallen leaf, poles, chimney, overhead transmission wires, nearby buildings, inter row shading etc which shade only a portion of the array. The schematic of all the shading scenarios used is presented in Fig. 5. For TCT-S array the performance under these partial shading conditions is investigated without as well as with bypass diode for the better understanding of the impact of bypass diode on output

power. For S-S array the output performance is observed only with bypass diode as this is the conventional configuration and all commercially available modules incorporates bypass diodes. One bypass diode per module has been implemented in the array.

4.2 Data measurement and processing

The output current-voltage and power-voltage curves for both the arrays are obtained under considered partial shading scenarios using Solmetric P-V Analyser when the natural irradiance was more than 850 W/m². However, owing to the environmental fluctuations, the value of irradiance and temperature for the recorded data varied. Therefore, for the comparative analysis, all the measured data is translated to standard conditions of 1000 W/m² and 25°C using the following translation equations specified in IEC 60891 [33].

$$I_{ref} = I_m + I_{scm} \cdot \left(\frac{G_{ref}}{G_m} - 1 \right) + \alpha \cdot (T_{ref} - T_m) \tag{11}$$

$$V_{ref} = V_m - R_s \cdot (I_{ref} - I_m) - \kappa \cdot I_{ref} \cdot (T_{ref} - T_m) + \beta \cdot (T_{ref} - T_m) \tag{12}$$

where, subscript ‘ref’ and ‘m’ refers to the reference and measured values respectively. ‘V’ is the voltage, ‘I’ is the current, ‘Isc’ is the short circuit current, ‘G’ is the solar irradiance, ‘T’ is the temperature, ‘Rs’ is the internal series resistance of the module, ‘α’ and ‘β’ are the current and voltage temperature coefficients of the module and κ is a curve correction factor.

4.3 Comparative performance

A comparative analysis is carried out for S-S array with bypass, TCT-S array without bypass and TCT-S array with bypass diodes on the basis of utilization factor, power loss sustained and power enhancement (PE) under various partial shading scenarios. These parameters are defined below [19, 34].

$$Utilization\ factor\ (\%) = \frac{P_{max(shadedarray)}}{\sum P_{max(modules)atSTC}} \times 100 \tag{13}$$

$$Power\ loss\ (\%) = \frac{P_{max(unshaded)} - P_{max(shaded)}}{P_{max(unshaded)}} \times 100 \tag{14}$$

$$PE\ (\%) = \frac{P_{max(TCT-S\ array)} - P_{max(S-S\ array)}}{P_{max(s-s\ array)}} \times 100 \tag{15}$$

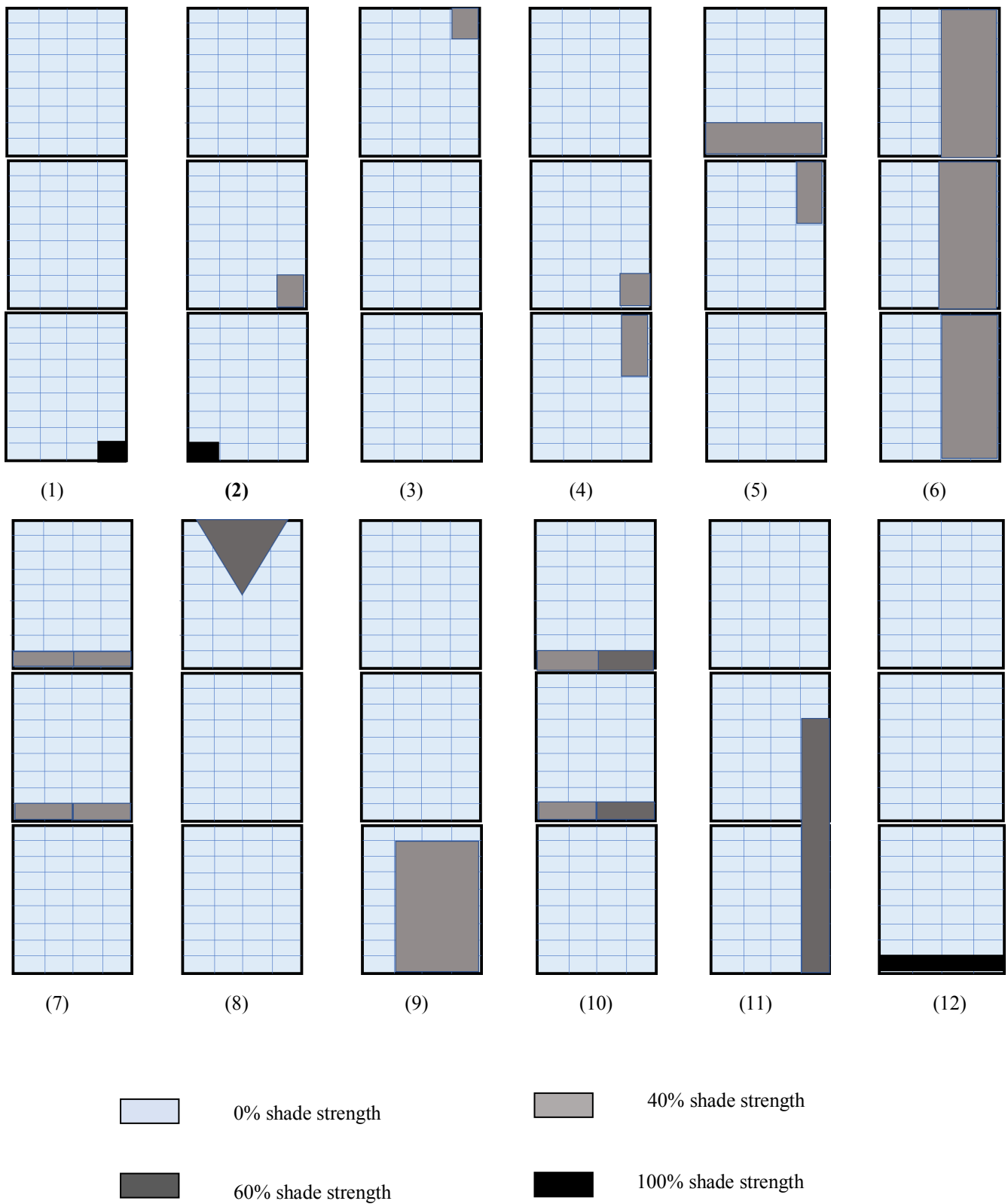

Fig. 5. Different shading scenarios considered.

Table 2. Comparative output power for S-S array and TCT-S array both without bypass diode.

Shading case	Output power (%)	
	S-S array	TCT-S array
Case I	0	89.3
Case II	0	65.0
Case III	0	36.1
Case IV	0	0

5. Results and Discussion

5.1. Comparative Performance Assessment of S-S and TCT-S Array under Shading Conditions Without Bypass Diode (Cell Failure)

The results obtained for this test conducted on S-S and TCT-S array, both without bypass diode is presented in Table 2. The results illustrate that novel TCT-S array has much higher fault tolerance due to shading than conventional S-S array. The maximum power of the TCT-S arrays without any shading in the field has been obtained as 143.9 Wp. With only one cell shaded to 100% strength (analogous to cell failure), the output of the TCT-S array drops to only 128.5 Wp, while the power of entire S-S array is dragged down to zero. With one cell failure, TCT-S array can still generate 90% of the power even in the absence of bypass diodes. This is because of the presence of cross ties which provides additional paths for the current to flow even when current is restricted in one branch due to cell failure. This is clearly not achieved in series configuration because of presence of only one current path. As this shading is progressed to two and three cells in a row, the output power obtained by TCT-S array is 93.5 Wp and 51.9 Wp respectively. When complete row i.e., all four cells are shaded with 100% strength (failure of four cells together) only then it is observed that output power of TCT-S array drops to zero in the absence of bypass diode. This is because in a TCT module, these shaded 4 parallelly connected cells in a row are in series with other parallel block of cells. As this TCT module fails to generate power, it brings down the power of the entire array. The obtained power output of S-S array under all these four cases is 0 W.

5.2. Comparative Performance Assessment of S-S Array And TCT-S Array Without and With Bypass Diode Under Partial Shading Conditions

The output power obtained from S-S array with bypass and TCT-S array without and with bypass under various shading scenarios is presented in Table 3. As previously mentioned in section 4.1.2, performance of TCT-S array without and with bypass diode has been compared to only S-S array with bypass. The case of S-S array without bypass diode under these 12 shading patterns has not been considered. The obtained results clearly demonstrates that in general TCT-S array with as well as without bypass diode generates much higher power than S-S array under all shading scenarios. The only exception is shading scenario 12 where TCT-S array without bypass doesn't generate power. But it is observed that in the presence of bypass diodes TCT-S array generates 60% of power, similar to S-S array.

The comparative utilization factor for the arrays under all the shading scenarios considered is presented in Fig. 6. The obtained results show that utilization of the array under partial shading conditions is more in the case of proposed TCT-S configuration than S-S configuration. It is observed that S-S configuration is utilized least (51.4%) for shading scenario 10 when the one row each of two modules within the array is shaded non uniformly. Under the same shading scenario, utilization factor for TCT-S array is 68.3% and 77.7% without bypass and with bypass diodes respectively. The maximum enhancement in utilization factor is seen for shading scenario 2. Under this shading condition, utilization factor of S-S array is only 56.4%, which is enhanced to 85.3% & 91.9% in case of TCT-S array without and with bypass diodes respectively.

Further, the power loss sustained by the arrays under different partial shading scenarios are presented in Fig. 7. It is evident from the obtained results that the conventional S-S array is highly susceptible to power loss under shading conditions. When one row each of two modules is shaded with strength 40% (scenario 7), S-S array sustains a power loss of 25.3%. The power loss incurred by TCT-S array under same shading is reduced to 18.6% & 14.2% without and with bypass diodes respectively. When the shading strength of only half of each row is increased to 60% (scenario 10), S-S power loss is increased to 48.3%. TCT-S displays power loss of 29.3% & 21.7% under same scenario without and with bypass diodes respectively. It is also observed for column wise shading (scenario 3, 4 & 6; shading strength 40%), S-S array sustains much higher power loss than proposed TCT-S array. The power loss exhibited by S-S array for shading cases 3, 4 & 6 is 20.9%, 20.3% & 34.5% respectively. For the same shading scenarios while TCT-S array without bypass diode exhibits just 3.3%, 4.5% & 20.4%, TCT-S with bypass diode further reduces it to 2.7%, 3.9% & 19.7% respectively. For shading scenario 11, again in which shade is distributed column wise but with

Table 3. Maximum output power, power loss and power enhancement (w.r.t S-S array) obtained by S-S and TCT-S array under various partial shading scenarios.

Shading scenario	S-S with BPD		TCT-S without BPD			TCT-S with BPD		
	P_{max} (W)	Power loss (%)	P_{max} (W)	Power loss (%)	Power Enhancement (W)	P_{max} (W)	Power loss (%)	Power Enhancement (W)
Case-1	102.0	29.3	127.9	11.1	25.9	133.3	7.4	31.3
Case-2	81.8	43.2	127.1	11.6	45.3	133.2	7.4	51.4
Case-3	114.0	20.9	139.2	3.3	25.2	140.0	2.7	26.0
Case-4	114.9	20.3	137.4	4.5	22.5	138.2	3.9	23.3
Case-5	107.3	25.5	110.9	22.9	3.6	120.1	16.5	12.8
Case-6	94.4	34.5	114.5	20.4	20.1	115.5	19.7	21.1
Case-7	110.8	23.1	113.7	21.0	2.9	123.9	13.9	13.1
Case-8	98.9	31.4	109.8	23.7	10.9	118.8	17.4	19.9
Case-9	107.6	25.3	117.1	18.6	9.4	123.5	14.2	15.8
Case-10	74.5	48.3	101.8	29.3	27.3	112.7	21.7	38.2
Case-11	90.6	37.2	135.7	5.7	45.2	136.1	5.4	45.5
Case-12	85.6	40.6	2.9	97.9	-85.6	85.7	40.4	0.03

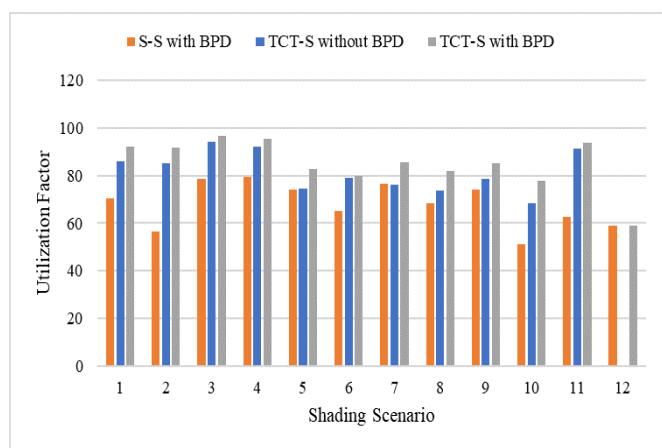

Fig 6. Utilization factor for the investigated arrays under considered shading scenarios.

strength 60%, S-S array suffer a power loss of 37.2% which is reduced to merely 5.7% & 5.4% in case of TCT-S array without bypass and with bypass diodes respectively. In general, novel TCT-S array under all partial shading scenarios sustains much less power loss in comparison to conventional S-S array.

The power enhancement achieved under all shading scenarios using the proposed TCT-S configuration without and with bypass w.r.t conventional S-S array with bypass diode is presented in bar chart in Fig. 8. The results show that for shading scenarios 2 & 11, highest power enhancement (equal or greater than 50%) is achieved by using novel TCT-S configuration with as well as without using bypass diodes. For shading scenario 12, as the TCT-S array doesn't generate any power in the absence of bypass diode, hence its enhancement is displayed as negative (-)100%. With bypass diodes TCT-S array power generation is same as S-S array, hence no power enhancement is shown. In general, power is enhanced under shading conditions by the proposed TCT-S array in comparison to S-S array.

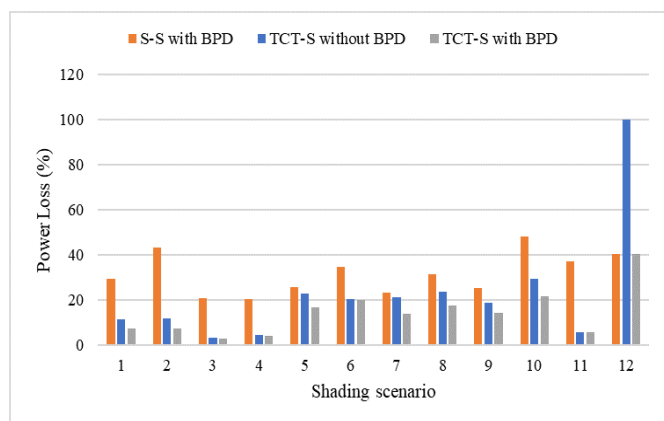

Fig 7. Power loss for the investigated arrays under considered shading scenarios.

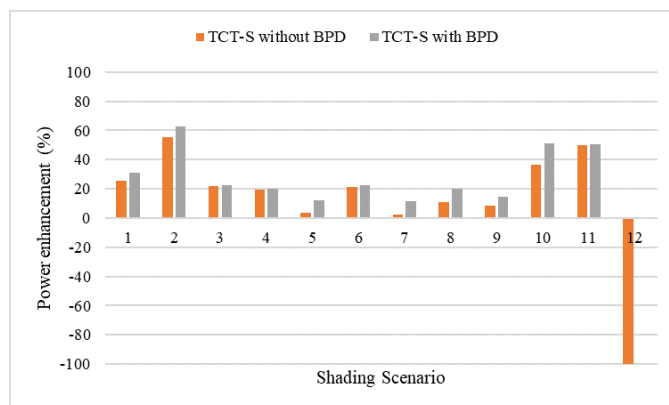

Fig. 8. Power enhancement obtained from TCT-S array without and with bypass diode w.r.t S-S array with bypass under considered shading scenarios.

5.3. Impact of Bypass Diode on the Output Performance of TCT-S Array

Performance of TCT-S array with and without bypass diode is observed under all shading scenarios. The obtained results reveal that in general the output power obtained from TCT-S array without and with bypass diode doesn't differ significantly. It is observed that when the shade is distributed column wise (shading scenario 3, 4 & 11), the power output obtained without and with bypass is approximately same (139.2 Wp, 140.0 Wp; 137.4 Wp, 138 Wp; 135.7 Wp, 136.1 Wp respectively). This is because of the presence of cross ties which already provide additional paths for the current to flow along with the one provided by bypass diode in conducting state. Even when one path gets restricted because of shading within the module, current is not restricted to flow. However, when the shade is distributed over the entire row of any TCT module in the array (shading scenarios 5, 7 & 10), the losses are observed to be somewhat higher than the other patterns. The obtained enhancement in the output power of TCT-S array by using bypass diodes is 6.4%, 7.6% & 7.1% for shading scenarios 5, 7 & 10 respectively. For shading scenario 12 where the entire row gets shaded with 100% strength, the presence of bypass diode has been found to be most important, producing power enhancement of 40% w.r.t to power without bypass diode. This is because in a TCT module, four cells in a row are parallelly connected and are in series with other parallel block of cells. When entire one or more rows within the array gets impacted with shading of higher strength, the role of bypass diode becomes significant.

5.4 Statistical Error

The uncertainty in repetition of obtained output power is estimated in terms of the deviations from the indoor measured power obtained using sun simulator at standard conditions of 1000 W/m² and 25°C. The same is presented in

terms of standard deviation (SD) and standard error (SE) in Table 4. The estimated uncertainty for indoor measurement of power is approximately 3% which has been reported in author's previous work [30].

6. Conclusion

The output power generation of a field installed PV array is severely affected by the frequently occurring partial shading conditions. In this paper a novel TCT-S configuration of PV array, which is the hybrid of total cross tied and series configuration, is presented to enhance the power generation of the PV array under partial shadings. An array of 145 Wp of the TCT-S configuration has been developed, implemented and studied experimentally in real outdoor conditions under various partial shading scenarios. The shading phenomenon has been considered at cell level rather than module which is a more realistic approach. The output performance of the novel configuration of PV array is investigated without and with bypass diodes, and compared to the conventional S-S array under partial shading conditions. It is substantiated from the obtained results that

Table 4. Statistical error sustained in estimating output power of different PV array configurations.

PV configuration	SD	SE
S-S array with BPD	0.265	0.037
TCT-S array without BPD	0.212	0.029
TCT-S array with BPD	0.214	0.029

TCT-S configured PV array has much superior flaw tolerance due to shading and produces higher power than S-S array under all shading scenarios. Even in the absence of bypass diode there are lesser chances of failure in TCT-S array as compared to conventional S-S array. In the absence of bypass diode, while the conventional array output power is dragged down to zero only with one cell failure, proposed TCT-S array can still generate approx. 90% power. A TCT-S array can fail to produce any power only when a complete row of cells is shaded with 100% strength. Performance of the novel configuration without and with bypass diode is observed under 12 diverse shading patterns ranging from only a single shaded cell in the array to extending over all the modules. The performance assessment is carried out in terms output power, power loss, utilization factor and power enhancement. The maximum power loss sustained by S-S array with bypass diodes is 48.3%. This loss is greatly reduced to 29.3% and 21.7% in case of TCT-S array without and with bypass diode respectively. The minimum power loss exhibited by S-S array in the presence of bypass diodes is 20.3% which reduces to just 4.5% and 3.9% in case of TCT-S array without and with bypass diode respectively. TCT-S array even in the absence of bypass diodes enhances the power in comparison to conventional array with bypass diodes. With bypass diodes attached, power is enhanced to some extent in those cases where entire row of the array gets shaded. While for column wise shading output power without and with bypass diodes is nearly same. To protect the array from extreme condition of module failure arising from complete row shading with 100% strength, bypass diodes can be implemented. However, in general the need of bypass diodes is less in the proposed array due to the multiple paths provided by the design of the proposed configuration.

The new configuration alleviates the power loss incurred due to partial shading and increase the efficiency of PV array only on the basis of the change in interconnection of cells. The proposed configuration is an easy to implement power loss mitigation strategy which doesn't exert additional cost burden on PV system and hence is of high practical significance to PV industry, solar project developers as well as customers.

Future scope of our study includes estimating annual energy yield of the proposed configuration. Also, this being a novel configuration authors also intend to conduct its long - term reliability analysis in future.

Acknowledgement

The authors are grateful to Dr. A.K. Tripathi, and Dr. Chandan Banerjee at National Institute of Solar Energy (NISE), Gurgaon under Ministry of New and Renewable Energy (MNRE), Government of India, India for allowing us to use the facilities for conducting this experimental study. Our sincere thanks are due to the staff at NISE for their support during this research work.

Funding

This research did not receive any specific grant from funding agencies in the public, commercial, or not-for-profit sectors.

References

- [1] W. Yin, Q. Tong, Y. Xu, Y. Zhang and Y. Zhou, "Partial Shading Impact on PV Array System and the Hard-Shading Location with BP Algorithm," 7th International Conference on Smart Grid (icSmartGrid), pp 21-26, 2019.
- [2] M. Davarifar, A. Rabhi, A. Hajjaji, E. Kamal and Z. Daneshifar, "Partial shading fault diagnosis in PV system with discrete wavelet transform (DWT)," International Conference on Renewable Energy Research and Application (ICRERA), pp 810-814, 2014.
- [3] H. Patel, V. Agarwal, "MATLAB-based modeling to study the effects of partial shading on PV array characteristics", IEEE Transactions on Energy Conversion, Vol. 23, pp 302–310, 2008.
- [4] K. Lappalainen, S. Valkealahti, "Output power variation of different PV array configurations during irradiance transitions caused by moving clouds" Applied Energy, Vol. 190, pp 902–910, 2017.
- [5] M. R. Maghami, H. Hizam, C. Gomes, M. A. Radzi, M. I. Rezadad, S. Hajjighorbani, "Power loss due to soiling on solar panel: A review", Renewable and Sustainable Energy Reviews, Vol. 59, pp 1307–1316, 2016.
- [6] J. Solis, A. Råberg, J. André and M. Nilsson, "Analyzing the effect of snow in PV regulator response in a PV solar park," 9th International Conference on Smart Grid (icSmartGrid), pp 72-75, 2021.
- [7] N. Varga, M. J. Mayor, "Model-based analysis of shading losses in ground-mounted photovoltaic power plants", Solar energy, Vol. 216, pp 428–438, 2021.
- [8] A. K. Behura, A. Kumar, D. K. Rajak, C. I. Pruncu, L. Lamberti, "Towards better performances for a novel rooftop solar PV system", Solar Energy, Vol. 216, pp518-529, 2021.
- [9] A. Calcabrini, R. Weegink, P. Manganiello, M. Zeman, O. Isabella, "Simulation study of the electrical yield of various PV module topologies in partially shaded urban scenarios", Solar Energy, Vol. 225, pp 726-733, 2021.
- [10] S. Sugumar, D. P. Winston, M. Pravin, "A novel on-time partial shading detection technique for electrical reconfiguration in solar PV system", Solar Energy, Vol. 225, pp 1009-1025, 2021.
- [11] D. P. Winston, S. Kumaravelb, B. P. Kumar, S. Devakirubakarand, "Performance improvement of solar PV array topologies during various partial shading conditions", Solar Energy, Vol. 196, pp 228-242, 2020.
- [12] A. Dolara, S. Leva, G. Magistrati, M. Mussetta, E. Ogliari and R. V. Arvind, "A novel MPPT algorithm for photovoltaic systems under dynamic partial shading — Recurrent scan and track method," IEEE International

- Conference on Renewable Energy Research and Applications (ICRERA), pp 1122-1127, 2016.
- [13] A. Belkaid, I. Colak, K. Kayisli and R. Bayindir, "Improving PV System Performance using High Efficiency Fuzzy Logic Control," 2020 8th International Conference on Smart Grid (icSmartGrid), pp 152-156, 2020.
- [14] N. D. Kaushika, N. K. Gautam, "Energy Yield Simulations of Interconnected Solar PV Arrays", IEEE Transactions on Energy Conversion, Vol. 18, No. 1, 2003.
- [15] R. Ramaprabha, B. L. Mathur, "A comprehensive review and analysis of solar photovoltaic array configurations under partial shaded conditions", International Journal of Photoenergy, Vol. 2012, Article ID 120214, 16 pages, 2012.
- [16] F. Belhachat, C. Larbes, "Modeling, analysis and comparison of solar photovoltaic array configurations under partial shading conditions", Solar Energy, Vol. 120, pp 399-418, 2015.
- [17] S. R. Pendem, S. Mikkili, "Modelling and performance assessment of PV array topologies under partial shading conditions to mitigate the mismatching power losses", Solar Energy, Vol. 160, pp 303-321, 2018.
- [18] O. Bingöl, B. Özkaya, "Analysis and comparison of different PV array configurations under partial shading conditions", Solar Energy, Vol. 160, pp 336-343, 2018.
- [19] S. Bana, R. P. Saini, "Experimental investigation on power output of different photovoltaic array configurations under uniform and partial shading scenarios", Energy, Vol. 127, pp 438-453, 2017.
- [20] M. Premkumar, U. Subramaniam, T. S. Babu, R. M. Elavarasan, L. Mihet-Popa, "Evaluation of Mathematical Model to Characterize the Performance of Conventional and Hybrid PV Array Topologies under Static and Dynamic Shading Patterns", Energies 13, no. 12: 3216. <https://doi.org/10.3390/en13123216>
- [21] V. Jha, U. S. Triar, "A detailed comparative analysis of different photovoltaic array configurations under partial shading conditions", International Transaction on Electrical Energy S2ystems, 2019; 29:e12020. <https://doi.org/10.1002/2050-7038.12020>
- [22] B. I. Rani, G. S. Ilango, C. Nagamani, "Enhanced power generation from PV array under partial shading conditions by Shade dispersion using Su Do Ku configuration", IEEE Transactions on Sustainable Energy, Vol. 4 (3), pp 594-601, 2013.
- [23] C. E. Ye, C. C. Tai, Y. P. Huang, J. J. Chen. "Dispersed partial shading effect and reduced power loss in a PV array using a complementary SuDoKu puzzle topology", Energy Conversion and Management, Vol. 246, 2021, 114675.
- [24] D. S. Pillai, J. P. Ram, V. Shabunko, Y. Kim, "A new shade dispersion technique compatible for symmetrical and unsymmetrical photovoltaic (PV) arrays", Energy, Vol. 225, 2021, 120241.
- [25] R. Pachauri, R. Singh, A. Gehlot, R. Samakaria, S. Choudhury, "Experimental analysis to extract maximum power from PV array reconfiguration under partial shading conditions", Engineering Science and Technology, an International Journal, Vol. 22, pp 109-130, 2019.
- [26] S. A. Yadav, K. R. Pachauri, K. Y. Chauhan, S. Chaudhury, R. Singh, "Performance enhancement of partially shaded PV array using novel shade dispersion effect on magic square puzzle configuration", Solar Energy, Vol. 144, pp 780-797, 2017.
- [27] G. Sagar, D. Pathak, P. Gaur, V. Jain, "A Su Do Ku puzzle-based shade dispersion for maximum power enhancement of partially shaded hybrid bridge-link-total-cross-tied PV array", Solar Energy, Vol. 204, pp 161-180, 2020.
- [28] V. M. R. Tatabhatla, A. Agarwal, T. Kanumuri, "Performance enhancement by shade dispersion of Solar Photo-Voltaic array under continuous dynamic partial shading conditions", Journal of Cleaner Production, Vol. 213, pp 462- 479, 2019.
- [29] D. P. Winston, G. Karthikeyan, P. Murugesan, O. JebaSingh, A. G. Akash, S. Nithish, S. Kabilan, "Parallel power extraction technique for maximizing the output of solar PV array", Solar Energy, Vol. 213, pp 102-117, 2021.
- [30] N. Agrawal, B. Bora, A. Kapoor, "Experimental investigation of fault tolerance due to shading in photovoltaic modules with different interconnected solar cell network", Solar Energy, Vol. 211, pp 1239-1254, 2020.
- [31] M. G. Villalva, J. R. Gazoli, E. R. Filho, "Comprehensive approach to modeling and simulation of photovoltaic arrays", IEEE Transactions on Power Electronics, Vol. 24 (5), pp 1198-1208, 2009 .
- [32] A. Jain, A. Kapoor. "Exact analytical solutions of the parameters of real solar cells using Lambert W-function", Solar Energy Material and Solar Cells, Vol.81, pp 269-277, 2004.
- [33] IEC 60891, 2009: Photovoltaic devices, Procedures for temperature and irradiance corrections to measured I-V Characteristics.
- [34] S. Vijayalekshmy, G. R. Bindu, S. R. Iyer, "A novel Zig-Zag scheme for power enhancement of partially shaded solar arrays", Solar Energy, Vol. 135, pp 92-102, 2016.